



Condron Concrete Works

CONDRON CONCRETE WORKS IS A TRADENAME FOR CONDRON CONCRETE LTD.

ARDEN ROAD, TULLAMORE, CO. OFFALY, IRELAND.

Condron Concrete Tile Brochure

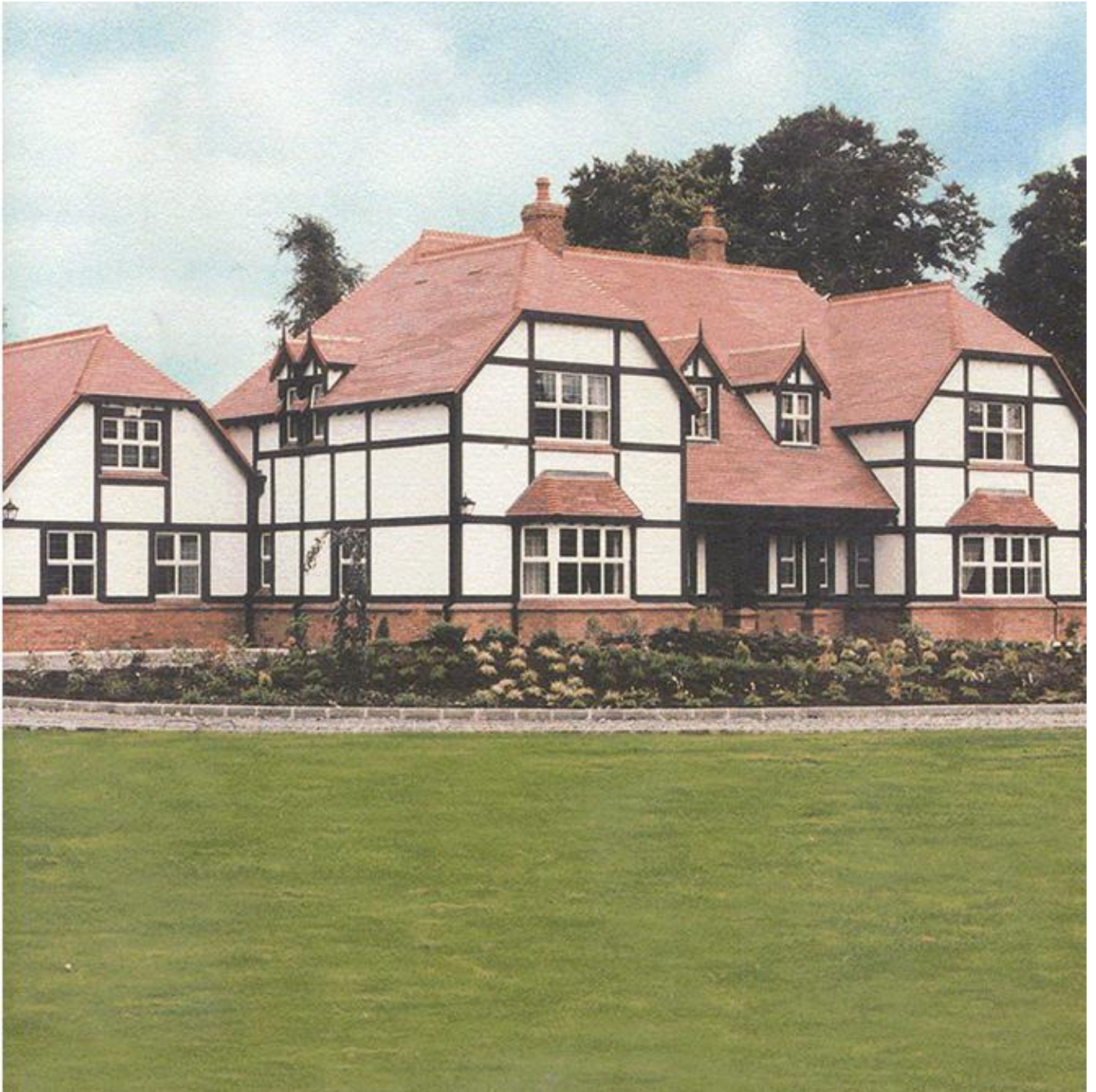

To “Top-Off” your investment!



Condron Concrete Works

CONDRON CONCRETE WORKS IS A TRADENAME FOR CONDRON CONCRETE LTD.

ARDEN ROAD, TULLAMORE, CO. OFFALY, IRELAND.

Contents

Contents	2
Double Pantile.....	4
Double Pantile technical Data.....	5
Low-Pitch Pantile.....	6
Low Pitch Pantile Technical Data.....	7
DR Tile	8
DR Tile Technical Data	9
Concrete Slate.....	10
Concrete Slate technical Data	11
Concrete Bullnose Slate.....	12
Concrete Bullnose Slate.....	13
3-in-1 Tile/Cladding Tile.....	14
3-in-1 Tile/Cladding Tile Technical Data	15
Plain Tile/Cladding Tile.....	16
Plain Tile/Cladding Tile Technical Data	17
M-Profile Tile	18
M-Profile Tile technical Data	19
Condron Slate	20
Condron Slate Technical Data	22
Senior Slate	23
Senior Slate Technical Data.....	25
Senior Bullnose Slate	26
Senior Bullnose Slate Technical Data.....	27
Colours Available	28
Accessories and Technical Specifications.....	30
Fixing (ROI)	34
Fixing (UK).....	35
Fixing (Details).....	36
Technical Drawings	40
Fixing Accessories	53
Roof Ventilation Recommendations	55
Over-Fascia Ventilation 10 & 25 mm	56
Eaves Comb Filler.....	57
Roll Out Rafter Trays.....	58
Ventilation – LV75 Vent Tile – Pantile/DR Tile	59
Ventilation – INV100 Inline Vent – 3-in-1 Tile.....	60
Ventilation – INV100 Inline Vent – Plain tile.....	61
Ventilation – INV100 Inline Vent – Pantile/DR Tile	62
LV200 Vent Tile – Pantile/DR Tile	63
Solar Tube Tile – TT – Plain Tile	64



Condron Concrete Works

CONDRON CONCRETE WORKS IS A TRADENAME FOR CONDRON CONCRETE LTD.

ARDEN ROAD, TULLAMORE, CO. OFFALY, IRELAND.

Contents - Continued

Dry Fix Ridge System Fitting Instructions.....	65
Continuous Dry Verge System	67
Continuous Dry Verge System Fitting Instructions	68
Dry Verge System – Uni-Click	71
Dry Verge System – Uni-Click Fitting Instructions	72
Dry Verge System – Aluminium Slate Dry verge.....	74
Dry Verge System – Aluminium Tile Dry Verge.....	75
Dry Valley System.....	76
Dry Valley System Fitting Instructions	78
GRP Valley System.....	80
Site Practice	81



Condron Concrete Works

CONDRON CONCRETE WORKS IS A TRADENAME FOR CONDRON CONCRETE LTD.
ARDEN ROAD, TULLAMORE, CO. OFFALY, IRELAND.

Condron Concrete Pantile



NOTE: Reference should be made to Code of Practice for Slating and Tiling, S.R. 82:2017, BS 5534:2014+A2: 2018 and any new code of practices in the future. Condron Concrete Roof Tiles are manufactured in compliance with E.N. 490:2011+A1: 2017 Concrete Roofing Tiles & Fittings.



Condron Concrete Works

CONDRON CONCRETE WORKS IS A TRADENAME FOR CONDRON CONCRETE LTD.

ARDEN ROAD, TULLAMORE, CO. OFFALY, IRELAND.

Technical Data for Pantile

Size	420mm X 330mm
Minimum roof pitch:	17.5° (see tables below)
Pitches Below	17.5° contact our Technical Department
Maximum gauge	345mm
Covering Capacity (at 345mm gauge net)	9.75 tiles per m ²
Surface	Smooth
Weight (approx.) per 1,000 tiles	4.5 tonnes
Laid weight per m ² (at 345mm gauge)	43.7 kg
Minimum batten sizes:	see tables below

Ireland

Minimum headlap below 30° (moderate exposure)	100mm
Minimum headlap at 30° & above (moderate exposure)	75mm
Minimum headlap at all roof pitches (severe exposure)*	100mm
Minimum batten size for rafters not exceeding 600mm c/c	47mm x 35mm

*superior underlay recommended

England, Scotland, Wales

Minimum headlap below 22.5°	100mm
Minimum headlap at 22.5° & above	75mm
Minimum batten size for rafters not exceeding 450mm c/c	38mm x 25mm
Minimum batten size for rafters not exceeding 600mm c/c	50mm x 25mm

Accessories Available

Tiles	Standard Tile, Half Tile.
Eaves	Standard Tile.
Ridge	Half Round, Universal Angle Ridge, High Pitch Angle Ridge, Ventilated Ridge, Dry-Fix Ridge, Ornamental Ridge, Universal Ornamental Shamrock Angle Ridge, High Pitch Ornamental Shamrock Angle Ridge, Universal Cocks Comb Ornamental Nagle Ridge, High Pitch Cocks Comb Ornamental Angle Ridge, Mono Ridge Tiles.
End Ridge	Universal Angle Ridge, Universal Angle hip End, Half Round Hip End, High Pitch Angle Ridge.
Hip	Universal Angle Ridge and High Pitch Angle Ridge, High Pitch Angle Ridge, Ornamental Ridge.
Verge	Verge Tile Left and Right, Verge Half Tile Left and Right, Dry Verge Uni Click, Continuous, Dry Verge, Mortar Bedded Verge.
Valley	Dry Valley, GRP Dry Valley, Mortar Bedded Valley.
Ventilation	Dry Ventilated Ridge, Over Fascia Ventilation, Eaves Comb Filler, Roll Out Rafter Trays, Undelay Protector, Quick-Flex Connector, Multi Adapter LV75 Vent Tile, LV200 Vent Tile, IV100 Inline Vent Tile
Solar	Solar Tube Tile - 1 Pipe & 2 Pipe.
Colours	Black, Grey, Brown, New Brown, Red, Marigold, Terracotta, Brown Streaky, Red Streaky, Marigold Streaky and Terracotta Streaky.
Nails	75mm X 9g A/Alloy
Clips	Batten Clips, Eaves Clips, Verge Clips, Hip Clips
Bedding	Coloured Pigments as required.

NOTE: Reference should be made to Code of Practice for Slating and Tiling, S.R. 82:2017, BS 5534:2014+A2: 2018 and any new code of practices in the future. Condron Concrete Roof Tiles are manufactured in compliance with E.N. 490:2011+A1: 2017 Concrete Roofing Tiles & Fittings.



Condron Concrete Works

CONDRON CONCRETE WORKS IS A TRADENAME FOR CONDRON CONCRETE LTD.
ARDEN ROAD, TULLAMORE, CO. OFFALY, IRELAND.

Condron 'Low Pitch' Pantile

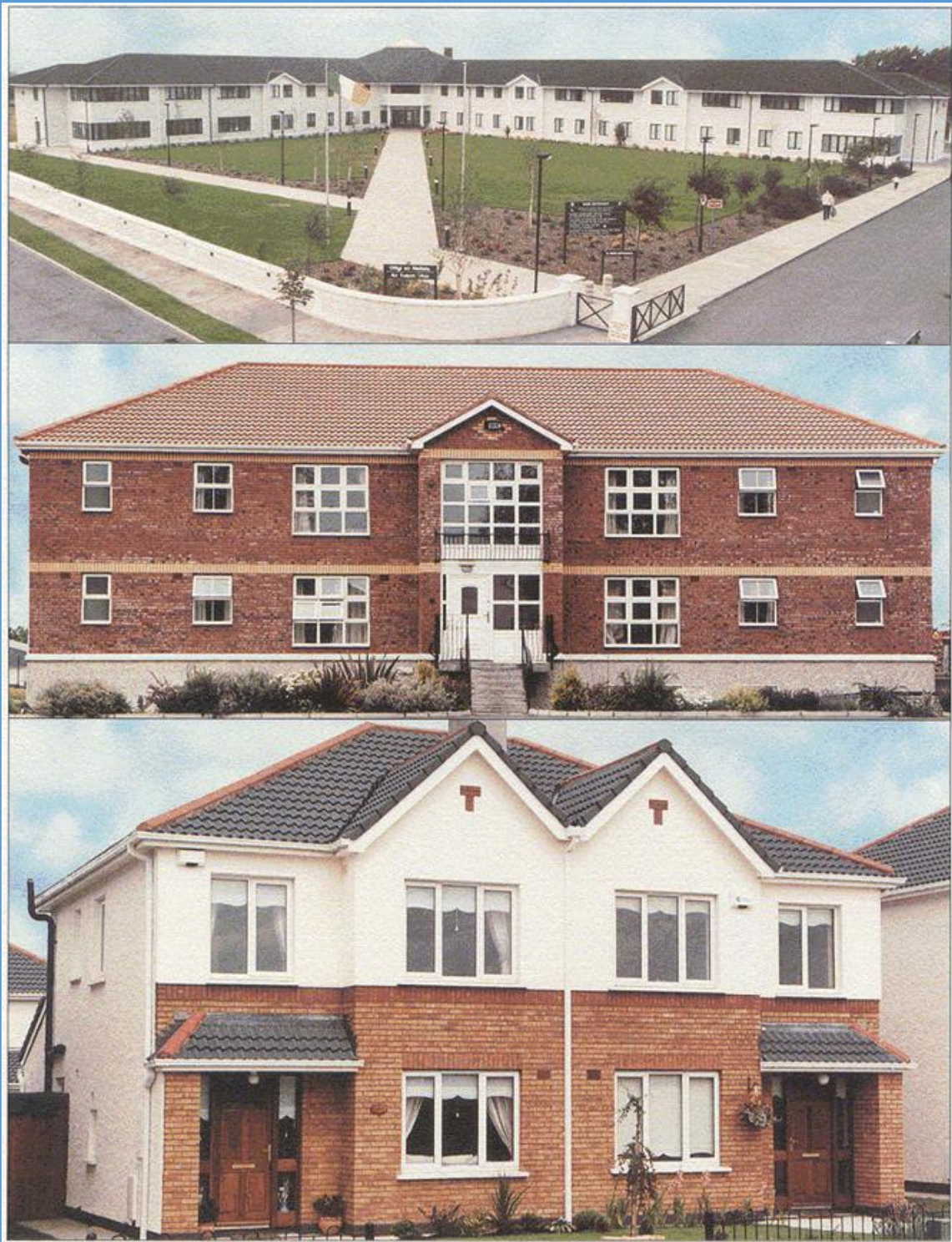

NOTE: Reference should be made to Code of Practice for Slating and Tiling, S.R. 82:2017, BS 5534:2014+A2: 2018 and any new code of practices in the future. Condron Concrete Roof Tiles are manufactured in compliance with E.N. 490:2011+A1: 2017 Concrete Roofing Tiles & Fittings.



Condron Concrete Works

CONDRON CONCRETE WORKS IS A TRADENAME FOR CONDRON CONCRETE LTD.

ARDEN ROAD, TULLAMORE, CO. OFFALY, IRELAND.

Technical Data for 'Low Pitch' Pantile

Size	420mm X 330mm
Minimum roof pitch:	12.5° (see tables below)
Pitches Below	12.5° contact our Technical Department
Maximum gauge	345mm
Covering Capacity (at 345mm gauge net)	9.75 tiles per m ²
Surface	Smooth
Weight (approx.) per 1,000 tiles	4.5 tonnes
Laid weight per m ² (at 345mm gauge)	43.7 kg
Minimum batten sizes:	see tables below

Ireland

Minimum headlap below 30° (moderate exposure)	100mm
Minimum headlap at 30° & above (moderate exposure)	75mm
Minimum headlap at all roof pitches (severe exposure)*	100mm
Minimum batten size for rafters not exceeding 600mm c/c	47mm x 35mm

*superior underlay recommended

England, Scotland, Wales

Minimum headlap below 22.5°	100mm
Minimum headlap at 22.5° & above	75mm
Minimum batten size for rafters not exceeding 450mm c/c	38mm x 25mm
Minimum batten size for rafters not exceeding 600mm c/c	50mm x 25mm

Note: It is recommended that water from higher roofs must not shed onto lower roofs; eg from valleys, abutments or gutter downpipes.

Accessories Available

Tiles	Standard Tile, Half Tile.
Eaves	Standard Tile.
Ridge	Half Round, Universal Angle Ridge, High Pitch Angle Ridge, Ventilated Ridge, Dry-Fix Ridge, Ornamental Ridge, Universal Ornamental Shamrock Angle Ridge, High Pitch Ornamental Shamrock Angle Ridge, Universal Cocks Comb Ornamental Nagle Ridge, High Pitch Cocks Comb Ornamental Angle Ridge, Mono Ridge Tiles.
End Ridge	Universal Angle Ridge, Universal Angle hip End, Half Round Hip End, High Pitch Angle Ridge.
Hip	Universal Angle Ridge and High Pitch Angle Ridge, High Pitch Angle Ridge, Ornamental Ridge.
Verge	Verge Tile Left and Right, Verge Half Tile Left and Right, Dry Verge Uni Click, Continuous, Dry Verge, Mortar Bedded Verge.
Valley	Dry Valley, GRP Dry Valley, Mortar Bedded Valley.
Ventilation	Dry Ventilated Ridge, Over Fascia Ventilation, Eaves Comb Filler, Roll Out Rafter Trays, Undelay Protector, Quick-Flex Connector, Multi Adapter LV75 Vent Tile, LV200 Vent Tile, IV100 Inline Vent Tile
Solar	Solar Tube Tile - 1 Pipe & 2 Pipe.
Colours	Black, Grey, Brown, New Brown, Red, Marigold, Terracotta, Brown Streaky, Red Streaky, Marigold Streaky and Terracotta Streaky.
Nails	75mm X 9g A/Alloy
Clips	Batten Clips, Eaves Clips, Verge Clips, Hip Clips
Bedding	Coloured Pigments as required.

NOTE: Reference should be made to Code of Practice for Slating and Tiling, S.R. 82:2017, BS 5534:2014+A2: 2018 and any new code of practices in the future. Condron Concrete Roof Tiles are manufactured in compliance with E.N. 490:2011+A1: 2017 Concrete Roofing Tiles & Fittings.



Condron Concrete Works

CONDON CONCRETE WORKS IS A TRADENAME FOR CONDRON CONCRETE LTD.

ARDEN ROAD, TULLAMORE, CO. OFFALY, IRELAND.

Condron Concrete DR Tile



NOTE: Reference should be made to Code of Practice for Slating and Tiling, S.R. 82:2017, BS 5534:2014+A2: 2018 and any new code of practices in the future. Condron Concrete Roof Tiles are manufactured in compliance with E.N. 490:2011+A1: 2017 Concrete Roofing Tiles & Fittings.



Condron Concrete Works

CONDRON CONCRETE WORKS IS A TRADENAME FOR CONDron CONCRETE LTD.

ARDEN ROAD, TULLAMORE, CO. OFFALY, IRELAND.

Technical Data for DR Tile

Size	420mm x 330mm
Minimum roof pitch:	17.5° (see tables below)
Pitches Below	17.5° contact our Technical department
Maximum gauge	345mm
Covering Capacity (at 345mm gauge net)	9.75 tiles per m ²
Surface	Smooth
Weight (approx.) per 1,000 tiles	4.5 tonnes
Laid weight per m ² (at 345mm gauge)	43.7 kg
Minimum batten sizes:	see tables below

Ireland

Minimum headlap below 30° (moderate exposure)	100mm
Minimum headlap at 30° & above (moderate exposure)	75mm
Minimum headlap at all roof pitches (severe exposure)*	100mm
Minimum batten size for rafters not exceeding 600mm c/c	47mm x 35mm

*superior underlay recommended

England, Scotland, Wales

Minimum headlap below 22.5°	100mm
Minimum headlap at 22.5° & above	75mm
Minimum batten size for rafters not exceeding 450mm c/c	38mm x 25mm
Minimum batten size for rafters not exceeding 600mm c/c	50mm x 25mm

Accessories Available

Tiles	Standard Tile, Half Tile.
Eaves	Standard Tile.
Ridge	Half Round, Universal Angle Ridge, High Pitch Angle Ridge, Ventilated Ridge, Dry-Fix Ridge, Ornamental Ridge, Universal Ornamental Shamrock Angle Ridge, High Pitch Ornamental Shamrock Angle Ridge, Universal Cocks Comb Ornamental Nagle Ridge, High Pitch Cocks Comb Ornamental Angle Ridge, Mono Ridge Tiles.
End Ridge	Universal Angle Ridge, Universal Angle hip End, Half Round Hip End, High Pitch Angle Ridge.
Hip	Universal Angle Ridge and High Pitch Angle Ridge, High Pitch Angle Ridge, Ornamental Ridge.
Verge	Verge Tile Left and Right, Verge Half Tile Left and Right, Dry Verge Uni Click, Continuous, Dry Verge, Mortar Bedded Verge.
Valley	Dry Valley, GRP Dry Valley, Mortar Bedded Valley.
Ventilation	Dry Ventilated Ridge, Over Fascia Ventilation, Eaves Comb Filler, Roll Out Rafter Trays, Undelay Protector, Quick-Flex Connector, Multi Adapter LV75 Vent Tile, LV200 Vent Tile, IV100 Inline Vent Tile
Solar	Solar Tube Tile - 1 Pipe & 2 Pipe.
Colours	Black, Grey, Brown, New Brown, Red, Marigold, Terracotta, Brown Streaky, Red Streaky, Marigold Streaky and Terracotta Streaky.
Nails	75mm X 9g A/Alloy
Clips	Batten Clips, Eaves Clips, Verge Clips, Hip Clips
Bedding	Coloured Pigments as required.

NOTE: Reference should be made to Code of Practice for Slating and Tiling, S.R. 82:2017, BS 5534:2014+A2:2018 and any new code of practices in the future. Condron Concrete Roof Tiles are manufactured in compliance with E.N. 490: 2011:+A1: 2017 Concrete Roofing Tiles & Fittings.



Condron Concrete Works

CONDRON CONCRETE WORKS IS A TRADENAME FOR CONDRON CONCRETE LTD.

ARDEN ROAD, TULLAMORE, CO. OFFALY, IRELAND.

Condron Concrete Slate Tile



NOTE: Reference should be made to Code of Practice for Slating and Tiling, S.R. 82:2017, BS 5534:2014+A2: 2018 and any new code of practices in the future. Condron Concrete Roof Tiles are manufactured in compliance with E.N. 490:2011+A1: 2017 Concrete Roofing Tiles & Fittings.



Condron Concrete Works

CONDRON CONCRETE WORKS IS A TRADENAME FOR CONDROn CONCRETE LTD.

ARDEN ROAD, TULLAMORE, CO. OFFALY, IRELAND.

Technical Data for Slate Tile

Size	420mm x 330mm
Minimum roof pitch:	22.5° (see tables below)
Pitches Below	22.5° contact our Technical department
Maximum gauge	345mm
Covering Capacity (at 345mm gauge net)	9.75 tiles per m ² at 345mm gauge 10.5 tiles per m ² at 320mm gauge
Surface	Smooth and Mock Line
Weight (approx.) per 1,000 tiles	5.0 tonnes
Laid weight per m ²	48.7 kg at 345mm gauge 52.5 kg at 320mm gauge
Minimum batten sizes:	see tables below

Ireland

Minimum headlap at all roof pitches (moderate exposure) ¹	100mm
Minimum headlap at all roof pitches (severe exposure)* ¹	100mm
Minimum batten size for rafters not exceeding 600mm c/c	47mm x 35mm

*superior underlay recommended ¹maximum 6 metre rafter length

England, Scotland, Wales

Minimum headlap at 22.5° & above ¹	75mm
Minimum batten size for rafters not exceeding 450mm c/c	38mm x 25mm
Minimum batten size for rafters not exceeding 600mm c/c	50mm x 25mm

¹maximum 6 metre rafter length

ACCESSORIES AVAILABLE:

Tiles	Standard Slate Tile, Half Slate Tile.
Eaves	Standard Slate Tile.
Ridge	Universal Angle Ridge, High Pitch Angle Ventilated Ridge, Dry-Fix Ridge, Ventilated Dry Ridge, Ornamental Ridge, Universal Ornamental Shamrock Angle Ridge, High Pitch Ornamental Shamrock Angle Ridge, Universal Cocks Comb Ornamental Nagle Ridge, High Pitch Cocks Comb Ornamental Angle Ridge Mono Ridge Tiles.
End Ridge	Universal Angle Ridge, Universal Angle Hip end, High Pitch Angle Ridge, Ornamental Ridge.
Hip	Universal Angle Ridge and High Pitch Angle Ridge, Dry Hip.
Verge	Verge Tile Left and Right, Verge Half Tile Left and Right, Dry Verge Uni Click, Continuous Dry Verge, Mortar Bedded Verge.
Valley	Dry Valley, GRP Dry Valley, Mortar Bedded Valley.
Ventilation	Dry Ventilated Ridge, Over Fascia Ventilation, Eaves Comb Filler, Roll Out Rafter Trays, Undelay Protector, Quick-Flex Connector, Multi Adapter LV75 Vent Tile, LV200 Vent Tile, IV100 Inline Vent Tile
Solar	Solar Tube Tile 1 Pipe & 2 Pipe.
Colours	Black, Grey, Brown, New Brown, Red, Marigold, Terracotta, Brown Streaky, Red Streaky, Marigold Streaky and Terracotta Streaky.
Nails	50mm X 9g A/Alloy
Clips	Batten Clips, Eaves Clips, Verge Clips, Hip Clips
Bedding	Coloured Pigments as required.

NOTE: Reference should be made to Code of Practice for Slating and Tiling, S.R. 82:2017, BS 5534:2014+A2: 2018 and any new code of practices in the future. Condron Concrete Roof Tiles are manufactured in compliance with E.N. 490:2011+A1: 2017 Concrete Roofing Tiles & Fittings.



Condron Concrete Works

CONDRON CONCRETE WORKS IS A TRADENAME FOR CONDRON CONCRETE LTD.

ARDEN ROAD, TULLAMORE, CO. OFFALY, IRELAND.

Condron Concrete Bullnose Slate Tile

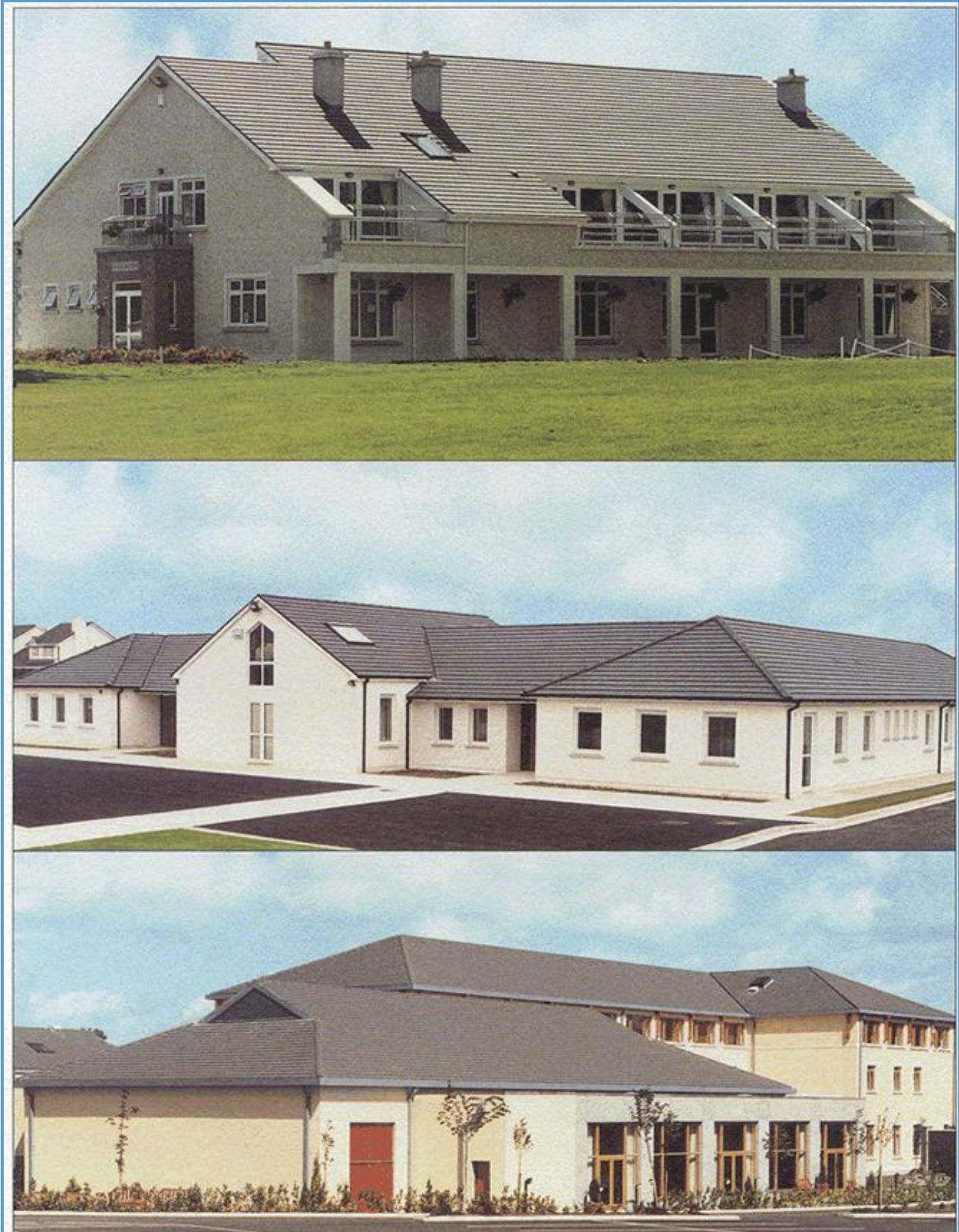

NOTE: Reference should be made to Code of Practice for Slating and Tiling, S.R. 82:2017, BS 5534:2014+A2: 2018 and any new code of practices in the future. Condron Concrete Roof Tiles are manufactured in compliance with E.N. 490:2011+A1: 2017 Concrete Roofing Tiles & Fittin



Condron Concrete Works

CONDRON CONCRETE WORKS IS A TRADENAME FOR CONDRON CONCRETE LTD.

ARDEN ROAD, TULLAMORE, CO. OFFALY, IRELAND.

Technical Data for Bullnose Slate Tile

Size	420mm x 330mm
Minimum roof pitch:	22.5° (see tables below)
Pitches Below	22.5° contact our Technical department
Maximum gauge	345mm
Covering Capacity (at 345mm gauge net)	9.75 tiles per m ² at 345mm gauge 10.5 tiles per m ² at 320mm gauge
Surface	Smooth and Mock Line
Weight (approx.) per 1,000 tiles	5.0 tonnes
Laid weight per m ²	48.7 kg at 345mm gauge 52.5 kg at 320mm gauge
Minimum batten sizes:	see tables below

Ireland

Minimum headlap at all roof pitches (moderate exposure) ¹	100mm
Minimum headlap at all roof pitches (severe exposure)* ¹	100mm
Minimum batten size for rafters not exceeding 600mm c/c	47mm x 35mm

¹superior underlay recommended ¹maximum 6 metre rafter length

England, Scotland, Wales

Minimum headlap at 22.5° & above ¹	75mm
Minimum batten size for rafters not exceeding 450mm c/c	38mm x 25mm
Minimum batten size for rafters not exceeding 600mm c/c	50mm x 25mm

¹maximum 6 metre rafter length

ACCESSORIES AVAILABLE:

Tiles	Standard Tile.
Eaves	Standard Tile.
Ridge	Universal Angle Ridge, High Pitch Angle Ridge, Baby Angle Ridge, Baby Half Round Ridge, Ventilated Ridge, Dry-Fix Ridge, Ventilated Dry Ridge, Ornamental Ridge, Universal Ornamental Shamrock Angle Ridge, High Pitch Ornamental Shamrock Angle Ridge, Universal Cocks Comb Ornamental Nagle Ridge, High Pitch Cocks Comb Ornamental Angle Ridge Mono Ridge Tiles.
End Ridge	Universal Angle Ridge, Universal Angle Hip End, High Pitch Angle Ridge, Ornamental Ridge.
Hip	Universal Angle Ridge and High Pitch Angle Ridge, Dry Hip.
Verge	Verge Tile Left and Right, Verge Half Tile Left and Right, Dry Verge Uni Click, Continuous Dry Verge, Mortar Bedded Verge.
Valley	Dry Valley, GRP Dry Valley, Mortar Bedded Valley.
Ventilation	Dry Ventilated Ridge, Over Fascia Ventilation, Eaves Comb Filler, Roll Out Rafter Trays, Undelay Protector, Quick-Flex Connector, Multi Adapter LV75 Vent Tile, LV200 Vent Tile, IV100 Inline Vent Tile
Solar	Solar Tube Tile 1 Pipe & 2 Pipe.
Colours	Black, Grey, Brown, New Brown, Red, Marigold, Terracotta, Brown Streaky, Red Streaky, Marigold Streaky and Terracotta Streaky.
Nails	50mm X 9g A/Alloy
Clips	Batten Clips, Eaves Clips, Verge Clips, Hip Clips
Bedding	Coloured Pigments as required.

NOTE: Reference should be made to Code of Practice for Slating and Tiling, S.R. 82:2017, BS 5534:2014+A2: 2018 and any new code of practices in the future. Condron Concrete Roof Tiles are manufactured in compliance with E.N. 490:2011+A1: 2017 Concrete Roofing Tiles & Fittings.



Condron Concrete Works

CONDRON CONCRETE WORKS IS A TRADENAME FOR CONDRON CONCRETE LTD.
ARDEN ROAD, TULLAMORE, CO. OFFALY, IRELAND.

Condron Concrete 3 in 1 Tile/Cladding Tile



NOTE: Reference should be made to Code of Practice for Slating and Tiling, S.R. 82:2017, BS 5534:2014+A2: 2018 and any new code of practices in the future. Condron Concrete Roof Tiles are manufactured in compliance with E.N. 490:2011+A1: 2017 Concrete Roofing Tiles & Fittings.



Condron Concrete Works

CONDRON CONCRETE WORKS IS A TRADENAME FOR CONDRON CONCRETE LTD.

ARDEN ROAD, TULLAMORE, CO. OFFALY, IRELAND.

Technical Data for 3 in 1 Tile/Cladding Tile

Size	265mm x 500mm
Minimum pitch	30°
Maximum gauge	100mm
Cover Width	500mm
Cover Capacity	100mm Gauge - 20 Tiles per m ² 95mm Gauge - 22 Tiles per m ² 90mm Gauge - 24 Tiles per m ²
Surface	Smooth
Weight (approx.) per 1,000 tiles	3.75 tonnes
Minimum batten sizes:	See tables below

Ireland

Minimum batten size for rafters not exceeding 400mm c/c	47mm x 22mm
Minimum batten size for rafters not exceeding 600mm c/c	47mm x 35mm

England, Scotland, Wales

Minimum batten size for rafters not exceeding 450mm c/c	38mm x 25mm
Minimum batten size for rafters not exceeding 600mm c/c	38mm x 25mm

ACCESSORIES AVAILABLE:

Tiles	Standard Tile, Tile and a Half, 200mm Eave/Top Tile.
Top Course	Single Course with 200mm Eave/Top Tile.
Eaves	Use Double Course at the Eaves with 200mm Eaves Top Tile. Eave/Top Tiles for the Undercourse.
Ridge	Universal Angle Ridge, High Pitch Angle Ridge, Baby Angle Ridge, Baby Half Round Ridge, Ventilated Ridge, Dry-Fix Ridge, Ventilated Dry Ridge, Ornamental Ridge, Universal Ornamental Shamrock Angle Ridge, High Pitch Ornamental Shamrock Angle Ridge, Universal Cocks Comb Ornamental Nagle Ridge, High Pitch Cocks Comb Ornamental Angle Ridge Mono Ridge Tiles.
End Ridge	Universal Angle Ridge, Universal Angle Hip End, High Pitch Angle Ridge, Ornamental Ridge.
Hip	Universal Angle Ridge and High Pitch Angle Ridge, Baby Angle Ridge, Baby Half Round Ridge, Dry Hip, Bonnet Hip – 3 in 1 Tiles
Verge	Verge Tile Full Tile, Verge Tile and a Half Continuous Dry Verge, Mortar Bedded Verge.
Valley	Dry Valley, GRP Dry Valley, Mortar Bedded Valley, Valley Tiles – 3 in 1 Tiles.
Ventilation	Dry Ventilated Ridge, Over Fascia Ventilation, Eaves Comb Filler, Roll Out Rafter Trays, Undelay Protector, Quick-Flex Connector, Multi Adapter INV100 Inline Vent Tile
Solar	Solar Tube Tile 1 Pipe & 2 Pipe.
Colours	Black, Grey, Brown, New Brown, Marigold, Terracotta, Brown Streaky, Red Streaky, Marigold Streaky, Terracotta Streaky and New Brown Streaky.
Nails	40mm x 9 g A/Alloy.
Clips	Batten Clips, Eaves Clips, Verge Clips, Hip Clips
Bedding	Coloured Pigments as required.

NOTE: Reference should be made to Code of Practice for Slating and Tiling, S.R. 82:2017, BS 5534:2014+A2: 2018 and any new code of practices in the future. Condron Concrete Roof Tiles are manufactured in compliance with E.N. 490:2011+A1: 2017 Concrete Roofing Tiles & Fittings.



Condron Concrete Works

CONDRON CONCRETE WORKS IS A TRADENAME FOR CONDRON CONCRETE LTD.

ARDEN ROAD, TULLAMORE, CO. OFFALY, IRELAND.

Condron Concrete Plain Tile/Cladding Tile



NOTE: Reference should be made to Code of Practice for Slating and Tiling, S.R. 82:2017, BS 5534:2014+A2: 2018 and any new code of practices in the future. Condron Concrete Roof Tiles are manufactured in compliance with E.N. 490:2011+A1: 2017 Concrete Roofing Tiles & Fittings.



Condron Concrete Works

CONDRON CONCRETE WORKS IS A TRADENAME FOR CONDRON CONCRETE LTD.

ARDEN ROAD, TULLAMORE, CO. OFFALY, IRELAND.

Technical Data for Plain Tile/Cladding Tile

Size	265mm X 165mm
Pitch	35° minimum
Gauge maximum	100mm
Cover Width	165mm
Cover Capacity	100mm Gauge - 60 Tiles per m ² 95mm Gauge - 64 Tiles per m ² 90mm Gauge - 68 Tiles per m ²
Surface	Smooth and Mock Line.
Weight (approx.) per 1,000 tiles	1.25 tonnes
Minimum batten sizes:	see tables below

Ireland

Minimum batten size for rafters not exceeding 400mm c/c	47mm x 22mm
Minimum batten size for rafters not exceeding 600mm c/c	47mm x 35mm

England, Scotland, Wales

Minimum batten size for rafters not exceeding 450mm c/c	38mm x 25mm
Minimum batten size for rafters not exceeding 600mm c/c	38mm x 25mm

ACCESSORIES AVAILABLE:

Tiles	Standard Tile, Tile and a Half, 200mm Eave/Top Tile.
Top Course	Single Course with 200mm Eave/Top Tile.
Eaves	Use Double Course at the Eaves with 200mm Eaves Top Tile. Eave/Top Tiles for the Undercourse.
Ridge	Universal Angle Ridge, High Pitch Angle Ridge, Dry-Fix Ridge, Ventilated Dry Ridge, Ornamental Ridge, Universal Ornamental Shamrock Angle Ridge, High Pitch Ornamental Shamrock Angle Ridge, Universal Cocks Comb Ornamental Nagle Ridge, High Pitch Cocks Comb Ornamental Angle Ridge Mono Ridge Tiles.
End Ridge	Universal Angle Ridge, Universal Angle Hip End, Half Round Hip End, High Pitch Angle Ridge, Ornamental Ridge.
Hip	Universal Angle Ridge and High Pitch Angle Ridge, Baby Angle Ridge, Baby Half Round Ridge, Dry Hip, Bonnet Hip.
Verge	Continuous Dry Verge, Mortar Bedded Verge.
Valley	Dry Valley, GRP Dry Valley, Mortar Bedded Valley, Valley Tiles.
Ventilation	Dry Ventilated Ridge, Over Fascia Ventilation, Eaves Comb Filler, Roll Out Rafter Trays, Undelay Protector, Quick-Flex Connector, Multi Adapter INV100 Inline Vent Tile.
Solar	Solar Tube Tile 1 Pipe & 2 Pipe.
Colours	Black, Grey, Brown, Marigold, Terracotta, Brown Streaky, Red Streaky and Marigold Streaky.
Nails	40mm X 9g A/Alloy.
Clips	Batten Clips, Eaves Clips, Verge Clips, Hip Clips.
Bedding	Coloured Pigments as required.

NOTE: Reference should be made to Code of Practice for Slating and Tiling, S.R. 82:2017, BS 5534:2014+A2: 2018 and any new code of practices in the future. Condron Concrete Roof Tiles are manufactured in compliance with E.N. 490:2011+A1: 2017 Concrete Roofing Tiles & Fittings.



Condron Concrete Works

CONDRON CONCRETE WORKS IS A TRADENAME FOR CONDRON CONCRETE LTD.
ARDEN ROAD, TULLAMORE, CO. OFFALY, IRELAND.

Condron Concrete M-Profile Tile



NOTE: Reference should be made to Code of Practice for Slating and Tiling, S.R. 82:2017, BS 5534:2014+A2: 2018 and any new code of practices in the future. Condron Concrete Roof Tiles are manufactured in compliance with E.N. 490:2011+A1: 2017 Concrete Roofing Tiles & Fittings.



Condron Concrete Works

CONDRON CONCRETE WORKS IS A TRADENAME FOR CONDRON CONCRETE LTD.

ARDEN ROAD, TULLAMORE, CO. OFFALY, IRELAND.

Technical Data for M-Profile tile

Size	420mm x 330mm
Minimum roof pitch:	17.5° (see tables below)
Pitches Below	17.5° contact our Technical Department
Maximum gauge	345mm
Covering Capacity (at 345mm gauge net)	9.75 tiles per m ²
Surface	Smooth
Weight (approx.) per 1,000 tiles	4.8 tonnes
Laid weight per m ² (at 345mm gauge)	46.8 kg
Minimum batten sizes:	see tables below

Ireland

Minimum headlap below 30° (moderate exposure)	100mm
Minimum headlap 30° & above (moderate exposure)	75mm
Minimum headlap at all roof pitches (severe exposure)*	100mm
Minimum batten size for rafters not exceeding 600mm c/c	47mm x 35mm

*superior underlay recommended

England, Scotland, Wales

Minimum headlap below 22.5°	100mm
Minimum headlap 22.5° & above	75mm
Minimum batten size for rafters not exceeding 450mm c/c	38mm x 25mm
Minimum batten size for rafters not exceeding 600mm c/c	50mm x 25mm

ACCESSORIES AVAILABLE:

Tiles	Standard Tile, Half Tile.
Eaves	Standard Tile.
Ridge	Half Round, Universal Angle Ridge, High Pitch Angle Ridge, Ventilated Ridge, Dry-Fix Ridge, Ventilated Dry Ridge, Ornamental Ridge, Universal Ornamental Shamrock Angle Ridge, High Pitch Ornamental Shamrock Angle Ridge, Universal Cocks Comb Ornamental Nagle Ridge, High Pitch Cocks Comb Ornamental Angle Ridge Mono Ridge Tiles.
End Ridge	Universal Angle Ridge, Universal Angle hip End, Half Round Hip End, High Pitch Angle Ridge, Ornamental Ridge.
Hip	Half Round, Universal Angle Ridge and High Pitch Angle Ridge, Dry Hip.
Verge	Verge Half Tile Left and Right, Dry Verge Uni Click, Continuous Dry Verge, Mortar Bedded Verge.
Valley	Dry Valley, GRP Dry Valley, Mortar Bedded Valley.
Ventilation	Dry Ventilated Ridge, Over Fascia Ventilation, Eaves Comb Filler, Roll Out Rafter Trays, Undelay Protector, Quick-Flex Connector, Multi Adapter LV75 Vent Tile, LV200 Vent Tile, IV100 Inline Vent Tile.
Solar	Solar Tube Tile 1 Pipe & 2 Pipe.
Colours	Black, Grey, Brown, New Brown, Red, Marigold, Terracotta, Brown Streaky, Red Streaky, Marigold Streaky and Terracotta Streaky.
Nails	50mm X 9g A/Alloy.
Clips	Batten Clips, Eaves Clips, Verge Clips, Hip Clips.
Bedding	Coloured Pigments as required.

NOTE: Reference should be made to Code of Practice for Slating and Tiling, S.R. 82:2017, BS 5534:2014+A2: 2018 and any new code of practices in the future. Condron Concrete Roof Tiles are manufactured in compliance with E.N. 490:2011+A1: 2017 Concrete Roofing Tiles & Fittings.



Condron Concrete Works

CONDRON CONCRETE WORKS IS A TRADENAME FOR CONDRON CONCRETE LTD.
ARDEN ROAD, TULLAMORE, CO. OFFALY, IRELAND.

The Condron Slate





Condron Concrete Works

CONDRON CONCRETE WORKS IS A TRADENAME FOR CONDRON CONCRETE LTD.

ARDEN ROAD, TULLAMORE, CO. OFFALY, IRELAND.





Condron Concrete Works

CONDRON CONCRETE WORKS IS A TRADENAME FOR CONDRON CONCRETE LTD.

ARDEN ROAD, TULLAMORE, CO. OFFALY, IRELAND.

Technical Data for Condron Slate

Size	300mm x 330mm
Minimum roof pitch:	25° (see tables below)
Pitches Below	25° contact our Technical department
Maximum gauge	206mm
Covering Capacity (at 206mm gauge net)	16 tiles per m ²
Surface	Smooth
Weight (approx.) per 1,000 tiles	2.7 tonnes
Laid weight per m ² (at 206mm gauge)	43.2 kg
Minimum batten sizes:	see tables below

Ireland

Minimum headlap at all roof pitches (moderate exposure) ¹	100mm
Minimum headlap at all roof pitches (severe exposure) ^{*1}	100mm
Minimum batten size for rafters not exceeding 600mm c/c	47mm x 35mm

**superior underlay recommended ¹maximum 6 metre rafter length*

England, Scotland, Wales

Minimum headlap at 25° & above ¹	94mm
Minimum batten size for rafters not exceeding 450mm c/c	38mm x 25mm
Minimum batten size for rafters not exceeding 600mm c/c	50mm x 25mm

¹maximum 6 metre rafter length

ACCESSORIES AVAILABLE:

Concrete Slates	Standard Slate, Half Slate.
Eaves	Standard Slate.
Ridge	Universal Angle Ridge, High Pitch Angle Ridge, Ventilated Ridge, Dry-Fix Ridge, Ventilated Dry Ridge, Ornamental Ridge, Universal Ornamental Shamrock Angle Ridge, High Pitch Ornamental Shamrock Angle Ridge, Universal Cocks Comb Ornamental Nagle Ridge, High Pitch Cocks Comb Ornamental Angle Ridge Mono Ridge Tiles.
End Ridge	Universal Angle Ridge, Universal Angle Hip End, High Pitch Angle Ridge, Ornamental Ridge.
Hip	Universal Angle Ridge and High Pitch Angle Ridge, Dry Hip.
Verge	Continuous Dry Verge, Mortar Bedded Verge.
Valley	Dry Valley, GRP Dry Valley, Mortar Bedded Valley.
Ventilation	Dry Ventilated Ridge, Over Fascia Ventilation, Eaves Comb Filler, Roll Out Rafter Trays, Undelay Protector, Quick-Flex Connector, Multi Adapter. IV100 Inline Vent Tile.
Solar	Solar Tube Tile 1 Pipe & 2 Pipe.
Colours	Black, Slate Grey, Brown, New Brown.
Nails	40mm x 3.35mm A/Alloy
Clips	Batten Clips, Eaves Clips, Verge Clips, Hip Clips.
Bedding	Coloured Pigments as required.

NOTE: Reference should be made to Code of Practice for Slating and Tiling, S.R. 82:2017, BS 5534:2014+A2: 2018 and any new code of practices in the future. Condron Concrete Roof Tiles are manufactured in compliance with E.N. 490:2011+A1: 2017 Concrete Roofing Tiles & Fittings.



Condron Concrete Works

CONDRON CONCRETE WORKS IS A TRADENAME FOR CONDRON CONCRETE LTD.

ARDEN ROAD, TULLAMORE, CO. OFFALY, IRELAND.

The Senior Slate



NOTE: Reference should be made to Code of Practice for Slating and Tiling, S.R. 82:2017, BS 5534:2014+A2: 2018 and any new code of practices in the future. Condron Concrete Roof Tiles are manufactured in compliance with E.N. 490:2011+A1: 2017 Concrete Roofing Tiles & Fittings.



Condron Concrete Works

CONDRON CONCRETE WORKS IS A TRADENAME FOR CONDRON CONCRETE LTD.

ARDEN ROAD, TULLAMORE, CO. OFFALY, IRELAND.

The Senior Slate



NOTE: Reference should be made to Code of Practice for Slating and Tiling, S.R. 82:2017, BS 5534:2014+A2: 2018 and any new code of practices in the future. Condron Concrete Roof Tiles are manufactured in compliance with E.N. 490:2011+A1: 2017 Concrete Roofing Tiles & Fittings.



Condron Concrete Works

CONDRON CONCRETE WORKS IS A TRADENAME FOR CONDRO CONCRETE LTD.

ARDEN ROAD, TULLAMORE, CO. OFFALY, IRELAND.

Technical Data for Senior Slate



Size	420mm x 330mm
Minimum roof pitch:	22.5° (see tables below)
Pitches Below	22.5° contact our Technical department
Maximum gauge	345mm
Covering Capacity (at 345mm gauge net)	9.75 tiles per m ² at 345mm gauge 10.5 tiles per m ² at 320mm gauge
Surface	Smooth & Mock Line
Weight (approx.) per 1,000 tiles	5.0 tonnes
Laid weight per m ²	48.7 kg at 345mm gauge 52.5 kg at 320mm gauge
Minimum batten sizes:	see tables below

Ireland

Minimum headlap at all roof pitches (moderate exposure) ¹	100mm
Minimum headlap at all roof pitches (severe exposure) ^{*1}	100mm
Minimum batten size for rafters not exceeding 600mm c/c	47mm x 35mm

^{*}superior underlay recommended ¹maximum 6 metre rafter length

England, Scotland, Wales

Minimum headlap at 22.5° & above ¹	75mm
Minimum batten size for rafters not exceeding 450mm c/c	38mm x 25mm
Minimum batten size for rafters not exceeding 600mm c/c	50mm x 25mm

¹maximum 6 metre rafter length

ACCESSORIES AVAILABLE:

Concrete Slates	Standard Slate, Half Slate.
Eaves	Standard Slate.
Ridge	Universal Angle Ridge, High Pitch Angle Ridge, Ventilated Ridge, Dry-Fix Ridge, Ventilated Dry Ridge, Ornamental Ridge, Universal Ornamental Shamrock Angle Ridge, High Pitch Ornamental Shamrock Angle Ridge, Universal Cocks Comb Ornamental Nagle Ridge, High Pitch Cocks Comb Ornamental Angle Ridge Mono Ridge Tiles.
End Ridge	Universal Angle Ridge, Universal Angle Hip End, High Pitch Angle Ridge, Ornamental Ridge.
Hip	Universal Angle Ridge and High Pitch Angle Ridge, Dry Hip.
Verge	Verge Half Slate Left and Right, Dry Verge Uni Click, Continuous Dry Verge, Mortar Bedded Verge.
Valley	Dry Valley, GRP Dry Valley, Mortar Bedded Valley.
Ventilation	Dry Ventilated Ridge, Over Fascia Ventilation, Eaves Comb Filler, Roll Out Rafter Trays, Undelay Protector, Quick-Flex Connector, Multi Adapter LV75 Vent Tile, LV200 Vent Tile, IV100 Inline Vent Tile.
Solar	Solar Tube Tile 1 Pipe & 2 Pipe.
Colours	Black and Grey.
Nails	50mm X 9g A/Alloy
Clips	Batten Clips, Eaves Clips, Verge Clips, Hip Clips.
Bedding	Coloured Pigments as required.

NOTE: Reference should be made to Code of Practice for Slating and Tiling, S.R. 82:2017, BS 5534:2014+A2: 2018 and any new code of practices in the future. Condron Concrete Roof Tiles are manufactured in compliance with E.N. 490:2011+A1: 2017 Concrete Roofing Tiles & Fittings.



Condron Concrete Works

CONDRON CONCRETE WORKS IS A TRADENAME FOR CONDRON CONCRETE LTD.

ARDEN ROAD, TULLAMORE, CO. OFFALY, IRELAND.

The Senior Bullnose Slate



NOTE: Reference should be made to Code of Practice for Slating and Tiling, S.R. 82:2017, BS 5534:2014+A2: 2018 and any new code of practices in the future. Condron Concrete Roof Tiles are manufactured in compliance with E.N. 490:2011+A1: 2017 Concrete Roofing Tiles & Fittings.



Condron Concrete Works

CONDRON CONCRETE WORKS IS A TRADENAME FOR CONDRON CONCRETE LTD.

ARDEN ROAD, TULLAMORE, CO. OFFALY, IRELAND.

Technical Data for Senior Bullnose Slate

Size	420mm x 330mm
Minimum roof pitch:	22.5° (see tables below)
Pitches Below	22.5° contact our Technical department
Maximum gauge	345mm
Covering Capacity (at 345mm gauge net)	9.75 tiles per m ² at 345mm gauge 10.5 tiles per m ² at 320mm gauge
Surface	Smooth & Mock line
Weight (approx.) per 1,000 tiles	5.0 tonnes
Laid weight per m ²	48.7 kg at 345mm gauge 52.5 kg at 320mm gauge
Minimum batten sizes:	see tables below

Ireland

Minimum headlap at all roof pitches (moderate exposure) ¹	100mm
Minimum headlap at all roof pitches (severe exposure)* ¹	100mm
Minimum batten size for rafters not exceeding 600mm c/c	47mm x 35mm

**superior underlay recommended ¹maximum 6 metre rafter length*

England, Scotland, Wales

Minimum headlap at 22.5° & above ¹	75mm
Minimum batten size for rafters not exceeding 450mm c/c	38mm x 25mm
Minimum batten size for rafters not exceeding 600mm c/c	50mm x 25mm

¹maximum 6 metre rafter length

ACCESSORIES AVAILABLE:

Concrete Slates	Standard Slate, Half Slate.
Eaves	Standard Slate.
Ridge	Universal Angle Ridge, High Pitch Angle Ridge, Ventilated Ridge, Dry-Fix Ridge, Ventilated Dry Ridge, Ornamental Ridge, Universal Ornamental Shamrock Angle Ridge, High Pitch Ornamental Shamrock Angle Ridge, Universal Cocks Comb Ornamental Nagle Ridge, High Pitch Cocks Comb Ornamental Angle Ridge Mono Ridge Tiles.
End Ridge	Universal Angle Ridge, Universal Angle Hip End, High Pitch Angle Ridge, Ornamental Ridge.
Hip	Universal Angle Ridge and High Pitch Angle Ridge, Dry Hip.
Verge	Verge Half Slate Left and Right, Dry Verge Uni Click, Continuous Dry Verge, Mortar Bedded Verge.
Valley	Dry Valley, GRP Dry Valley, Mortar Bedded Valley.
Ventilation	Dry Ventilated Ridge, Over Fascia Ventilation, Eaves Comb Filler, Roll Out Rafter Trays, Undelay Protector, Quick-Flex Connector, Multi Adapter LV75 Vent Tile, LV200 Vent Tile, IV100 Inline Vent Tile.
Solar	Solar Tube Tile 1 Pipe & 2 Pipe.
Colours	Black and Grey.
Nails	50mm X 9g A/Alloy
Clips	Batten Clips, Eaves Clips, Verge Clips, Hip Clips.
Bedding	Coloured Pigments as required.



NOTE: Reference should be made to Code of Practice for Slating and Tiling, S.R. 82:2017, BS 5534:2014+A2: 2018 and any new code of practices in the future. Condron Concrete Roof Tiles are manufactured in compliance with E.N. 490:2011+A1: 2017 Concrete Roofing Tiles & Fittings.



Condron Concrete Works

CONDRON CONCRETE WORKS IS A TRADENAME FOR CONDRON CONCRETE LTD.

ARDEN ROAD, TULLAMORE, CO. OFFALY, IRELAND.

Colours Available

Pantile Low Pitch Pantile DR Tile								
Slate Tile Bullnose Slate Tile								
Senior Slate Senior Bullnose Slate								
Condron Slate								
M-profile Tile								
3 in 1 Tile Cladding Tile								

Minor shade and colour variations may occur between batches of tiles. Therefore, we recommend that tiles are mixed from at least 3 pallets on site. The colours shown here are only as accurate as allowed for by the printing process. Product samples are available on request.

Note that under the influence of natural weathering, changes in surface colour and appearance will occur, resulting in a patchy roof. Black colour in particular tends to fade sooner than other colours, giving a chequered effect.



Condron Concrete Works

CONDRON CONCRETE WORKS IS A TRADENAME FOR CONDRON CONCRETE LTD.

ARDEN ROAD, TULLAMORE, CO. OFFALY, IRELAND.

Accessories & Technical Specifications

UNIVERSAL CONCRETE ANGLE RIDGE		
Pitches Length External Width External Height Weight Surface Colours Bedding Material	17.5 degrees to 37 degrees approx. 500mm 250mm 100mm 6.6 kilos approx. Smooth Terracotta, Brown, Grey, Black, Marigold and Red. Coloured pigments as required.	
UNIVERSAL CONCRETE ANGLE RIDGE HIP END		
	For use with Universal Concrete Angle ridges at the hip in colours to match the ridges	
HIGH PITCH CONCRETE ANGLE RIDGE		
Pitches Length External Width External Height Weight Surface Colours Bedding Material	37 degrees to 50 degrees approx. 500mm 250mm 140mm 8.2 kilos approx. Smooth Terracotta, Brown, Grey, Black, Marigold and Red. Coloured pigments as required.	
HALF ROUND CONCRETE RIDGE		
Pitches Length External Width External Height Weight Surface Colours Bedding Material	Universal 412mm 250mm 100mm 5.8 kilos approx. Smooth Terracotta, Brown, Grey, Black, Marigold, Brick Red & Red. Coloured pigments as required.	
HALF ROUND RIDGE HIP END		
	For use with Half Round Concrete ridges at the hip in colours to match the ridges	
UNIVERSAL ORNAMENTAL SHAMROCK ANGLE RIDGE		
Pitches Length External Width External Height Weight Surface Colours Bedding Material	17.5 degrees to 37 degrees approx. 500mm 250mm 100mm 6.6 kilos approx. Smooth Terracotta, Brown, Grey, Black, Marigold and Red. Coloured pigments as required.	









Condron Concrete Works

CONDRON CONCRETE WORKS IS A TRADENAME FOR CONDRON CONCRETE LTD.

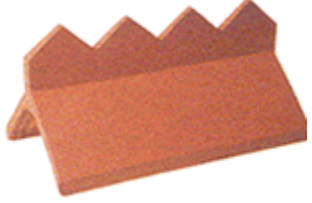
ARDEN ROAD, TULLAMORE, CO. OFFALY, IRELAND.

Accessories & Technical Specifications

HIGH PITCH ORNAMENTAL SHAMROCK ANGLE RIDGE		
Pitches	37 degrees to 50 degrees approx.	
Length	500mm	
External Width	250mm	
External Height	140mm	
Weight	8.2 kilos approx.	
Surface	Smooth	
Colours	Terracotta, Brown, Grey, Black, Marigold and Red.	
Bedding Material	Coloured pigments as required.	
UNIVERSAL COCKS COMB ORNAMENTAL ANGLE RIDGE		
Pitches	17.5 degrees to 37 degrees approx.	
Length	500mm	
External Width	250mm	
External Height	100mm	
Weight	6.6 kilos approx.	
Surface	Smooth	
Colours	Terracotta, Brown, Grey, Black, Marigold and Red.	
Bedding Material	Coloured pigments as required.	
HIGH PITCH COCKS COMB ORNAMENTAL ANGLE RIDGE		
Pitches	37 degrees to 50 degrees approx.	
Length	500mm	
External Width	250mm	
External Height	140mm	
Weight	8.2 kilos approx.	
Surface	Smooth	
Colours	Terracotta, Brown, Grey, Black, Marigold and Red.	
Bedding Material	Coloured pigments as required.	
VENTILATED RIDGE TILES		
Pitches	Universal	
Length	500mm	
External Width	250mm	
External Height	100mm	
Weight	6.6 kilos approx.	
Surface	Smooth	
Colours	Terracotta, Brown, Grey, Black, Marigold and Red.	
Bedding Material	Coloured pigments as required.	
MONO RIDGE TILES		
Length	450mm	
Surface	Smooth	
Colours	Black, Brown, Grey, Terracotta, Marigold and Brick Red.	
Bedding Material	Coloured pigments as required.	
BABY ANGLE RIDGE		
Length	300mm	
External Width	150mm	
Surface	Smooth	
Colours	Black, Brown, Grey, Terracotta, Marigold and Brick Red.	
Bedding Material	Coloured pigments as required.	



Condron Concrete Works

CONDRON CONCRETE WORKS IS A TRADENAME FOR CONDRON CONCRETE LTD.

ARDEN ROAD, TULLAMORE, CO. OFFALY, IRELAND.

BABY HALF ROUND RIDGE		
Length External Width Surface Colours Bedding Material	300mm 150mm Smooth Black, Brown, Grey, Terracotta, Marigold and Brick Red. Coloured pigments as required.	
BONNET HIP		
Surface Colours Bedding Material	Smooth Black, Brown, Grey, Terracotta, Marigold and Brick Red. Coloured pigments as required.	
VALLEY TILES		
Surface Colours Bedding Material	Smooth Black, Brown, Grey, Terracotta, Marigold and Brick Red. Coloured pigments as required.	
90 DEGREE EXTERNAL ANGLE		<div style="display: flex; justify-content: space-around;"> <div style="text-align: center;"> <p>Left</p>  </div> <div style="text-align: center;"> <p>Right</p>  </div> </div>
Surface Colours Bedding Material	Smooth Black, Brown, Grey, Terracotta, Marigold and Brick Red. Coloured pigments as required.	
135 DEGREE EXTERNAL ANGLE		<div style="display: flex; justify-content: space-around;"> <div style="text-align: center;"> <p>Left</p>  </div> <div style="text-align: center;"> <p>Right</p>  </div> </div>
Surface Colours Bedding Material	Smooth Black, Brown, Grey, Terracotta, Marigold and Brick Red. Coloured pigments as required.	
HALF CLOAK PANTILE		
Length External Width Surface Colours Bedding Material	420mm 165mm Approx. Smooth Black, Brown, Grey, Terracotta, Marigold and Brick Red. Coloured Pigments as required.	
HALF TILES PANTILE		
Length External Width Surface Colours Bedding Material	420mm 165mm Approx. Smooth Black, Brown, Grey, Terracotta, Marigold and Brick Red. Coloured pigments as required.	



Fixing (ROI)

Reference should be made to S.R. 82:2017 Slating and Tiling - Code of Practice and any current revisions

GENERAL:

PANTILE, LOW PITCH PANTILE & DR TILE

All tiles at perimeters and each tile in every alternate course to be nailed or clipped (nails and clips supplied by Condron Concrete Works). In the case of roof pitches over 45 degrees, and on exposed roofs, each tile to be nailed and clipped. For roof pitches below 25 degrees, all tiles must be clipped. For roof pitches below 25 degrees and on exposed sites, consideration should be given to the design of the roof, and designers and users should contact our technical sales office for advice.

SLATE TILE & BULLNOSE SLATE TILE

Tiles are laid broken jointed, and all tiles at perimeters and each tile in every alternate course should be nailed or clipped. In the case of roof pitches of 45 degrees or above, and on exposed roofs, each tile to be nailed and clipped. For roof pitches below 25 degrees, all tiles to be clipped. For roof pitches below 25 degrees and on exposed sites, consideration should be given to the design of the roof, and designers, and users, should contact our technical sales office for advice.

SENIOR SLATE & SENIOR BULLNOSE SLATE

Tiles are laid broken jointed, and all tiles at perimeters and each tile in every alternate course should be nailed or clipped. In the case of roof pitches over 45 degrees, and on exposed roofs, each slate to be nailed and clipped. For roof pitches below 25 degrees and on exposed sites, consideration should be given to the design of the roof, and designers and users should contact our technical sales office for advice.

M-PROFILE TILE.

Tiles are laid broken jointed, and all tiles at perimeters and each tile in every alternate course should be nailed or clipped. In the case of roof pitches of 45 degrees or above, and on exposed roofs, each tile to be nailed and clipped. For roof pitches below 25 degrees, all tiles to be clipped. For roof pitches below 25 degrees and on exposed sites, consideration should be given to the design of the roof, and designers, and users, should contact our technical sales office for advice.

CONDRON SLATE

Tiles are laid broken jointed, and all tiles at perimeters and each tile in every alternate course should be nailed or clipped. In the case of roof pitches over 45 degrees, and on exposed roofs, each slate to be nailed and clipped. For roof pitches below 25 degrees and on exposed sites, consideration should be given to the design of the roof, and designers and users should contact our technical sales office for advice. The Condron Slate should be treated with the same regard as a natural slate, and roof ladders should be used when fitting of maintenance is required.

3-IN-1 TILE / CLADDING TILE

All perimeter tiles at rafter pitches to 45 degrees, to be fixed with 40mm 9 gauge aluminium nails, (1 No. nail at each other edge per tile) and at least every tile in every fifth course to be nailed with 40mm 9 gauge aluminium nails (1 No. nail at each other edge per tile). For rafter pitches of 45 degrees and above and on exposed roofs, every tile in every course to be fixed with 40mm aluminium nails (1 No. nail at each other edge of tile).

PLAIN TILE / CLADDING TILE

All perimeter tiles, to a minimum of 600mm wide / deep on rafter pitch below 45 degrees to be fixed with 1 No. 40mm 9 gauge aluminium nail per tile, and every tile in every fifth row to be fixed with 1 No. 40mm 9 gauge aluminium nail per tile. For rafter pitches of 45 degrees and over and on exposed roofs, every tile in every course to be fixed with 1 No. 40mm aluminium nail per tile.



Fixing (UK)

GENERAL:

PANTILE, LOW PITCH PANTILE & DR Tile

Tiles are laid straight-bonded. All tiles at perimeters must be twice fixed; ie nail, screw, clip, or dry verge. All tiles in the local and general areas must be fixed (ie nailed or clipped). For roof pitches 45 degrees & over, all tiles must be nailed. For roof pitches 55 degrees & over, all tiles must be nailed and clipped. In addition, a calculation must be carried out to determine if extra fixings are required. Contact our Technical Sales office for advice.

SLATE TILE & BULLNOSE SLATE TILE

Tiles are laid broken jointed. All tiles at perimeters must be twice fixed; ie nail, screw, clip, or dry verge. All tiles in the local and general areas must be fixed (ie nailed or clipped). For roof pitches 45 degrees & over, all tiles must be nailed. For roof pitches 55 degrees & over, all tiles must be nailed and clipped. In addition, a calculation must be carried out to determine if extra fixings are required. Contact our Technical Sales office for advice.

SENIOR SLATE & SENIOR BULLNOSE SLATE

Tiles are laid broken jointed. All tiles at perimeters must be twice fixed; ie nail, screw, clip, or dry verge. All tiles in the local and general areas must be fixed (ie nailed or clipped). For roof pitches 45 degrees & over, all tiles must be nailed. For roof pitches 55 degrees & over, all tiles must be nailed and clipped. In addition, a calculation must be carried out to determine if extra fixings are required. Contact our Technical Sales office for advice.

M-PROFILE TILE.

Tiles are laid broken jointed. All tiles at perimeters must be twice fixed; ie nail, screw, clip, or dry verge. All tiles in the local and general areas must be fixed (ie nailed or clipped). For roof pitches 45 degrees & over, all tiles must be nailed. For roof pitches 55 degrees & over, all tiles must be nailed and clipped. In addition, a calculation must be carried out to determine if extra fixings are required. Contact our Technical Sales office for advice.

CONDRON SLATE

Tiles are laid broken jointed. All tiles at perimeters must be twice fixed; ie nail, screw, clip, or dry verge. All tiles in the local and general areas must be fixed (ie nailed or clipped). For roof pitches 45 degrees & over, all tiles must be nailed. For roof pitches 55 degrees & over, all tiles must be nailed and clipped. In addition, a calculation must be carried out to determine if extra fixings are required. Contact our Technical Sales office for advice. The Condron Slate should be treated with the same regard as a natural slate, and roof ladders should be used when fitting or maintenance is required.

CONCRETE 3 IN 1 TILE / CLADDING TILE

All tiles at verges, side abutments, hips and valleys must be twice nailed. At eaves, ridge and top abutments, all tiles in the first/last two courses must be twice nailed. In the local and general roof areas, each tile in every fifth course must be twice nailed. For roof pitches 60 degrees & over, all tiles must be twice nailed. In addition, a calculation must be carried out to determine if extra fixings are required. Contact our Technical Sales office for advice.

CONCRETE PLAIN TILE / CLADDING TILE

All tiles at verges, side abutments, hips and valleys must be twice nailed. At eaves, ridge and top abutments, all tiles in the first/last two courses must be twice nailed. In the local and general roof areas, each tile in every fifth course must be twice nailed. For roof pitches 60 degrees & over, all tiles must be twice nailed. In addition, a calculation must be carried out to determine if extra fixings are required. Contact our Technical Sales office for advice.



Fixing (Details)

VERGE

CONCRETE PANTILE

(a) The dry verge to be fitted with Condron Concrete Half Cloak Concrete Verge Tile. (If required a Half Pantile is available.) (b) P.V.C. dry verge to be fixed as per manufacturer's instructions. (c) The verges are formed with 150mm wide fibre cement strip undercloak, bedded in coloured mortar (pigments supplied by Condron Concrete Works) and to project 38mm to 50mm over gable wall or barge board.

CONCRETE SLATE TILE & "BULLNOSE" SLATE TILE

(a) The dry verge to be fitted with Condron Concrete Half Cloak Concrete Verge Tile. (b) P.V.C. dry verge to be fixed as per manufacturer's instructions. (c) The verges are formed with 150mm wide fibre cement strip undercloak, bedded in coloured mortar (pigments supplied by Condron Concrete Works) and to project 38mm to 50mm over gable wall or barge board.

THE SENIOR SLATE

(a) The dry verge to be fitted with Condron Concrete Half Cloak Concrete Verge Tile. (b) P.V.C. dry verge to be fixed as per manufacturer's instructions. (c) The verges are formed with 150mm wide fibre cement strip undercloak, bedded in coloured mortar (pigments supplied by Condron Concrete Works) and to project 38mm to 50mm over gable wall or barge board.
Condron JP Verge Piece.

CONCRETE 'M' PROFILE TILE

(a) The dry verge 3m section with the clover piece to be fitted (b) P.V.C. dry verge to be fixed as per manufacturer's instructions. (c) The verges are formed with 150mm wide fibre cement strip undercloak, bedded in coloured mortar (pigments supplied by Condron Concrete Works) and to project 38mm to 50mm over gable wall or barge board.

THE CONDRO SLATE

(a) The dry verge 3m section with the clover piece to be fitted (b) P.V.C. dry verge to be fixed as per manufacturer's instructions. (c) The verges are formed with 150mm wide fibre cement strip undercloak, bedded in coloured mortar (pigments supplied by Condron Concrete Works) and to project 38mm to 50mm over gable wall or barge board.

CONCRETE 3 IN 1 TILE / CLADDING TILE

(a) All verges to be laid broken – bonded with full tiles and tile -and- a half in alternate courses. (b) The dry verge to be fixed in accordance with manufacturer's instruction. (c) The verges are formed with 150mm wide fibre cement slate undercloak, bedded in mortar (pigments if required, supplied by Condron Concrete

Works) to project 38mm to 50mm over gable wall or barge board.

CONCRETE PLAIN TILE/ CLADDING TILE

(a) All verges to be laid broken-bonded, with full tiles and tile-and-a-half in alternate courses. (b) The dry verge to be fitted in accordance with the manufacturer's instruction. (c) The verges are formed with 150mm wide fibre cement undercloak, bedded in mortar (pigments if required, supplied by Condron Concrete Works) to project 38mm to 50mm over gable wall or barge board.



Fixing (Details)

EAVES

CONCRETE PANTILE / SLATE TILE / "BULLNOSE" SLATE TILE / THE SENIOR SLATE / THE CONDRON SLATE / CONCRETE 'M' PROFILE.

The eaves are formed with standard tiles. The first course of tiles is laid over the fascia board to the centre line of gutter, and this eave course must be laid at the same pitch as the rest of the roof. The design of a bellcast or sprocket at the eave is not recommended in single lap tiles.

CONCRETE 3 IN 1 TILE / CLADDING TILE / PLAIN TILE

At the eaves, use double course throughout using 200mm Eave / Top Tile for the undercourse to give the same overhang as the last main tile. Bellcasts at eaves can be used in 3 in 1 / Plain Tiles and designers and users should contact our technical sales office for advice.

TOP EDGE

CONCRETE PLAIN TILE / 3 IN 1 TILE.

At the top edge, the Eave / Top Tile should be fixed on the top course by nailing to the top batten.

APPLIES TO ALL ROOF TILES

Underlay:

Underlay provides a barrier to reduce the wind load on the roof tiles. It must have adequate resistance to prevent undue deflection and avoid contact with the undersides of the roof tiles. The underlay layer must also be waterproof and prevent penetration of wind-driven rain, snow and dust that may enter the batten cavity through the tiling and drain any water into the roof drainage system.

If Type 1F bituminous underlay is used, either Type 5U or a proprietary carrier must be used where the underlay is otherwise exposed at the eaves. Type 1F and Type 5U should conform to BS 8747:2007.

Vapour permeable or air permeable underlays in compliance with IS EN 13859-1 can be used, ensuring compliance with the manufacturer's recommendations. To overcome potential condensation risks, an air and vapour control layer should be installed on the warm side of the insulation.

For roof pitches below 25° and/or rafter lengths over 6 metres, superior quality underlay should be used; obtain advice from the underlay manufacturer.

For underlays laid unsupported over rafters, the minimum horizontal laps are as follows: below 22.5°; 225mm, 22.5° to 34.5°; 150mm, 35° and above; 100mm. Sidelaps should be located over a rafter and should 100mm or above.

The underlay should be fixed with clout nails and draped to allow drainage of water under tile battens between rafters. Ideally, use proprietary underlay support trays to extend into the gutters and support the underlay behind the fascias.

Care should be taken to avoid damaging the underlay, and any damage done must be repaired before fixing the tiles. Consider using counterbattens with bituminous nail tape between the underlay and tile battens. This will reduce the risk of water penetration through the underlay where the battens are nailed into the rafters and will enhance air movement within the batten cavity, thus reducing the risk of efflorescence forming on the undersides of the roof tiles.

RIDGE:

The ridge to be covered with Condron's Half Round Ridge, Universal Angle Ridge, or High Pitch Angle Ridge, similar colour and texture to the roof tiles, edge bedded on the tiles, with solid bedding at butt joints. All mortar bedded ridge tiles must be mechanically fixed. (Appropriate measures should be taken to achieve a proper bond).

DRY RIDGE:

The ridge to be covered with Condron's Half Round Ridge, Universal Angle Ridge, or High Pitch Angle Ridge, similar colour and texture to the roof tiles. All Ridge Tiles should be mechanically fixed in accordance with the manufacturer's instructions. Each ridge tile includes a central fixing hole to allow for an additional screw fixing, ensuring secure installation.



Condron Concrete Works

CONDRON CONCRETE WORKS IS A TRADENAME FOR CONDRON CONCRETE LTD.

ARDEN ROAD, TULLAMORE, CO. OFFALY, IRELAND.

HIPS:

The hips to be covered with Condron's Half Round Ridge, Universal Angle Ridge, High Pitch Angle Ridge and Bonnet Hip in matching colours. All Hip Tiles should be edge bedded onto the tiles, with solid bedding at butt joints.

DRY HIP:

The hips to be covered with Condron's Half Round Ridge, Universal Angle Ridge, High Pitch Angle Ridge with Hip End ridge and Bonnet Hip in matching colours. All Hip Tiles should be fixed in accordance with the manufacturer's instructions.

VALLEY:

Valley board should be fitted flush with valley rafters for best practice. Valley to be fitted in accordance with the manufacturer's instructions.

GRP VALLEY:

Valley board should be fitted flush with valley rafters for best practice. GRP Valley to be fitted in accordance with the manufacturer's instructions.

DRY VALLEY:

Valley board should be fitted flush with valley rafters for best practice. Dry Valley to be fitted in accordance with the manufacturer's instructions.

ABUTMENTS:

The tiles must be cut closely at the abutments, with a cover flashing dressed well down onto the adjacent tiles. Special attention should be given to detailing of flashings, and underlay felt, at abutments, chimneys, roof lights, valleys etc.

VENTILATION:

Roof space should be properly ventilated, as roofs not properly ventilated can result in condensation or efflorescence. Ref: CODE OF PRACTICE FOR SLATING AND TILING, S.R. 82:2017, BS 5534, BS 5250 and any new Irish Code of Practices in the future.

EFFLORESCENCE RISK:

Efflorescence occurs naturally on concrete products. It is important to install low and high-level roof-space ventilation when using air and vapour underlays to reduce the amount of water vapour entering the batten cavity (the space between the tiles and underlay) to minimise the risk of efflorescence forming on the undersides of the tiles. At eaves, install Condron OFV Over Fascia Ventilation system. At ridge, install Condron Dry Ventilated Ridge system, ensuring that the underlay is set back from the ridge apex by at least 30mm each side to allow a free flow of air out from the roof space.

In addition, consider providing batten cavity ventilation at low through to high level, combined with 25mm deep counterbattens to remove water vapour which enters the batten cavity. For further information, [click here](#) for our comprehensive video on 'How to reduce the risk of roof tile efflorescence'.

NOTE: All vents are supplied with an underlay protector, which must be inserted above any opening in the underlay to protect the underlay from water ingress into the roof void.

ACCESSORIES AVAILABLE:

Soil pipe ventilators, Tile vents, Roof lights, Eave fillers, Dry Verge, Clips, Nails, Ventilated ridge, Rectangle soffit vent, Strip vent, Roof space vent, Over fascia vent, Roof tile paint, Coloured pigments.

CLIMATIC CONDITIONS:

The colour of the roof tiles will weather over a period due to exposure, site location and weather conditions. The degree and pace of change is dependent upon weather conditions, pitch and site location.

NOTE: Reference should be made to Code of Practice for Slating and Tiling, S.R. 82:2017, BS 5534:2014+A2: 2018 and any new code of practices in the future. Condron Concrete Roof Tiles are manufactured in compliance with E.N. 490:2011+A1: 2017 Concrete Roofing Tiles & Fittings.



Condron Concrete Works

CONDRON CONCRETE WORKS IS A TRADENAME FOR CONDRON CONCRETE LTD.

ARDEN ROAD, TULLAMORE, CO. OFFALY, IRELAND.





Condron Concrete Works

CONDRON CONCRETE WORKS IS A TRADENAME FOR CONDRON CONCRETE LTD.

ARDEN ROAD, TULLAMORE, CO. OFFALY, IRELAND.

Technical Drawings

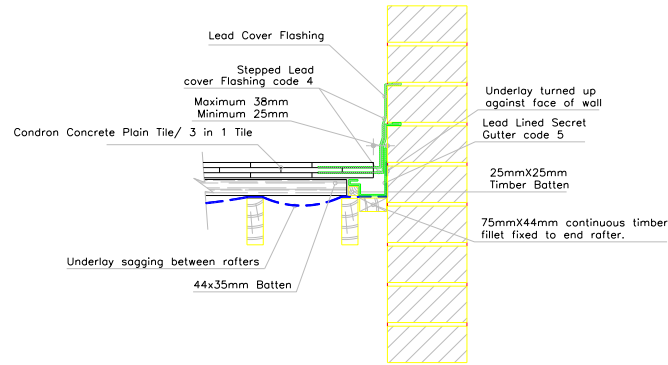

Abutment with Apron Flashing and side Gutter

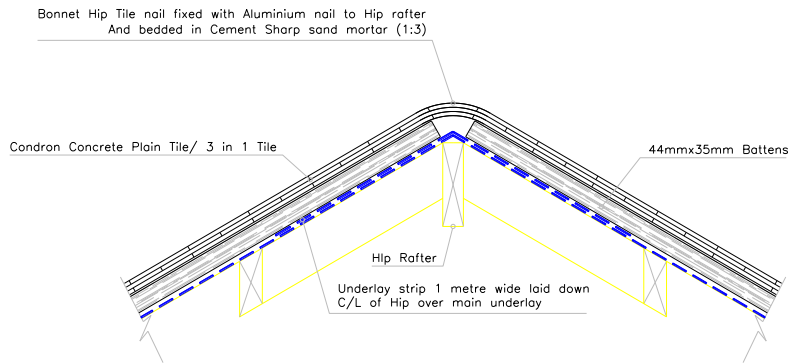

Bonnet Hip (Plain Tile/3 in 1 Tile)

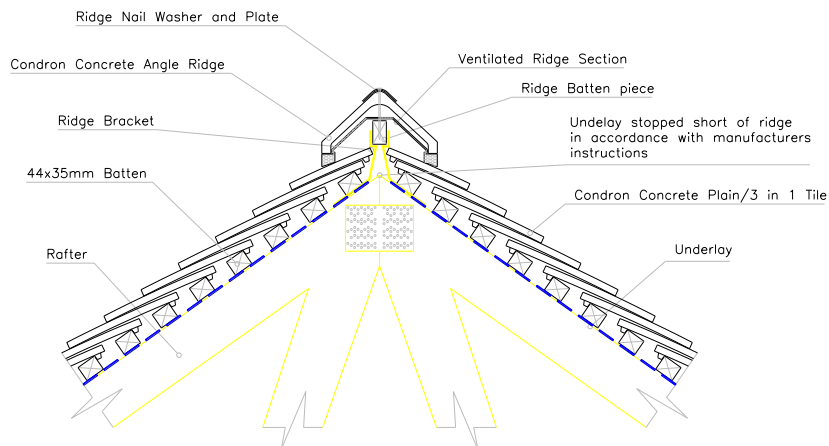

Dry Ridge System (Plain Tile / 3 in 1 Tile)

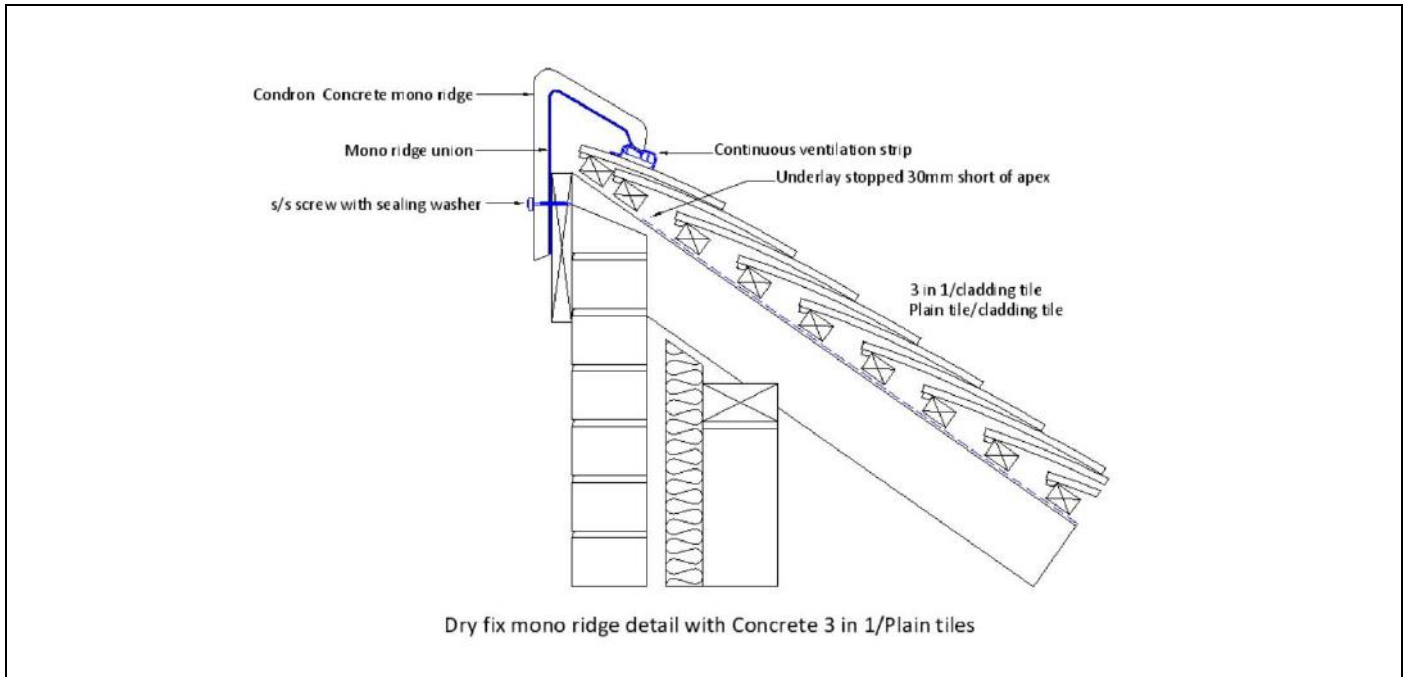

NOTE: Reference should be made to Code of Practice for Slating and Tiling, S.R. 82:2017, BS 5534:2014+A2: 2018 and any new code of practices in the future. Condron Concrete Roof Tiles are manufactured in compliance with E.N. 490:2011+A1: 2017 Concrete Roofing Tiles & Fittings.

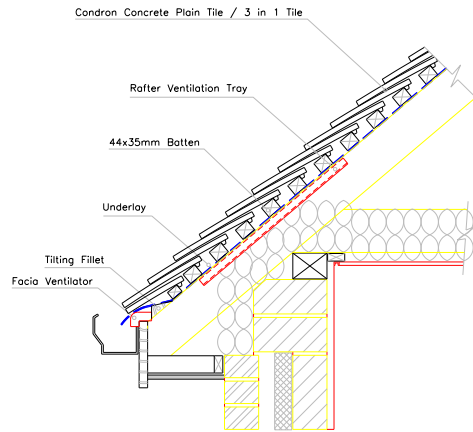

Eaves Ventilation (Plain Tile / 3 in 1 Tile)

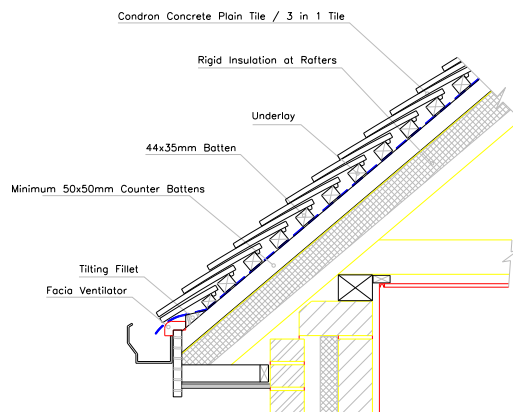

Eaves Ventilation Insulation at Rafter Level (Plain Tile / 3 in 1 Tile)

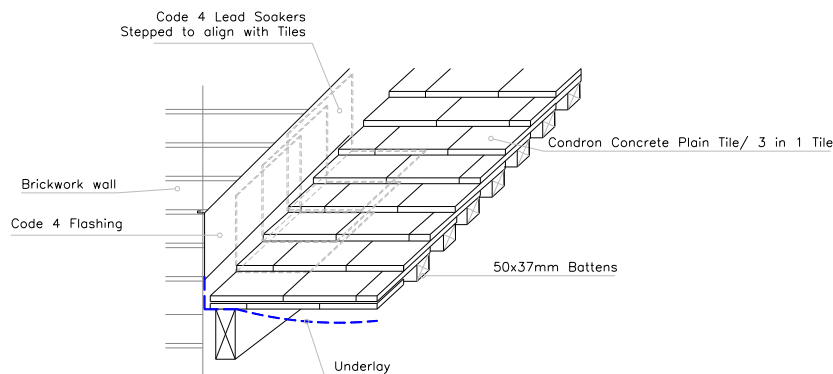

Abutment with Lead Soakers (Plain Tile / 3 in 1 Tile)

NOTE: Reference should be made to Code of Practice for Slating and Tiling, S.R. 82:2017, BS 5534:2014+A2: 2018 and any new code of practices in the future. Condron Concrete Roof Tiles are manufactured in compliance with E.N. 490:2011+A1: 2017 Concrete Roofing Tiles & Fittings.

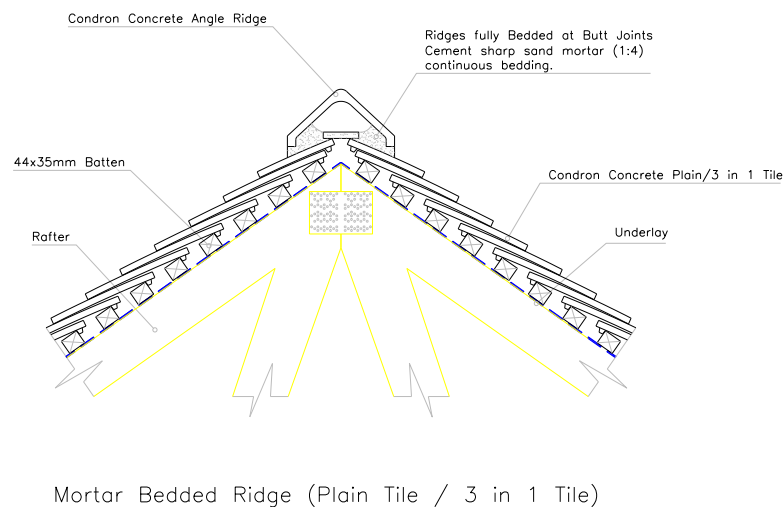
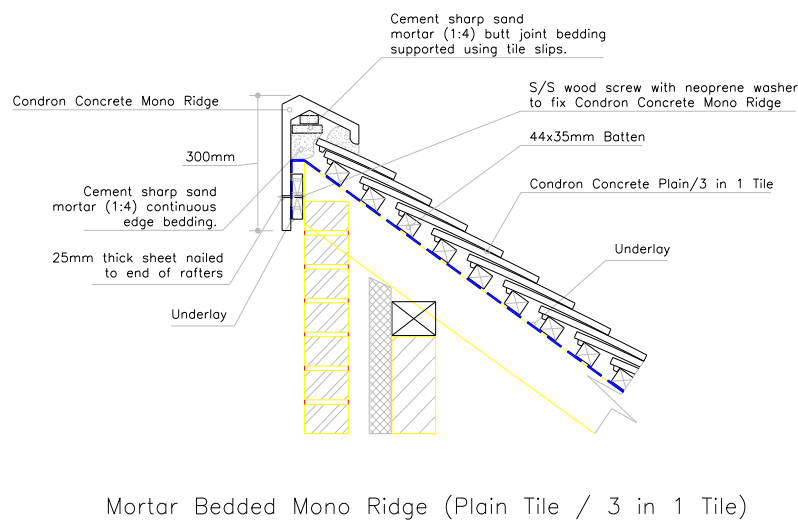
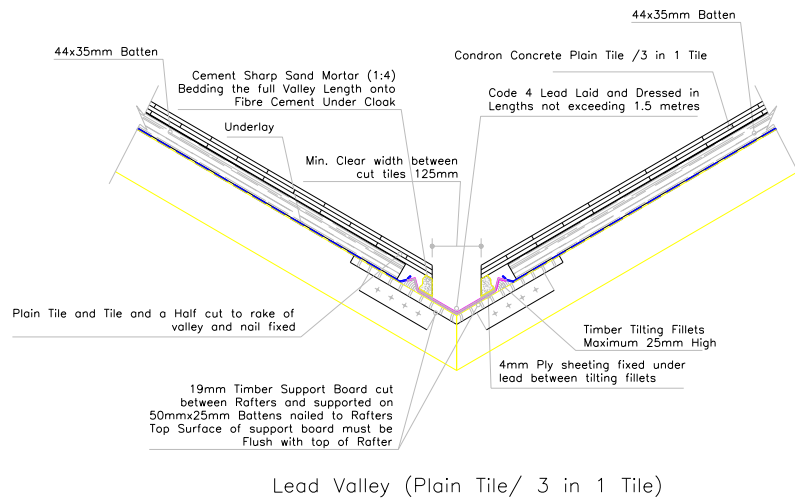

Note: all mortar bedded ridge and hip tiles must be mechanically fixed using screws or nails

NOTE: Reference should be made to Code of Practice for Slating and Tiling, S.R. 82:2017, BS 5534:2014+A2: 2018 and any new code of practices in the future. Condron Concrete Roof Tiles are manufactured in compliance with E.N. 490:2011+A1: 2017 Concrete Roofing Tiles & Fittings.

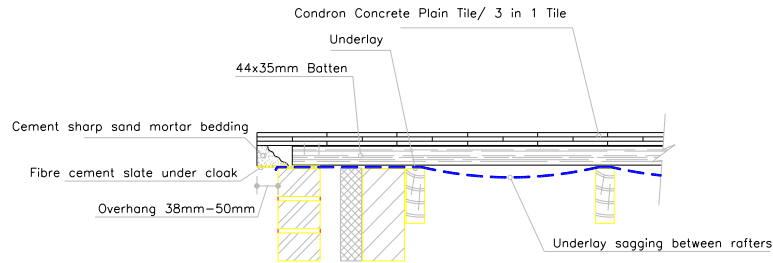

Mortar Bedded Verge (Plain tile/ 3 in 1)

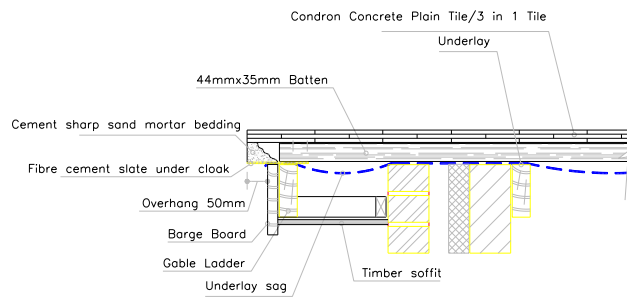

Mortar Bedded Verge with Barge Over-Hang(Plain Tile/ 3 in 1)

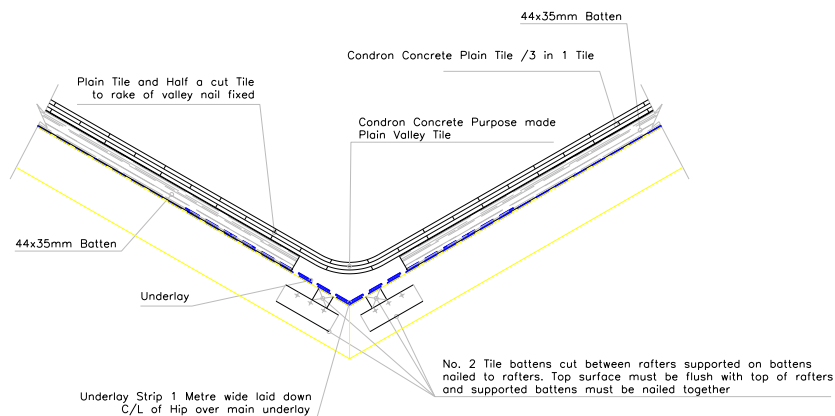

Plain Tile/3 in 1 Tile Valley

NOTE: Reference should be made to Code of Practice for Slating and Tiling, S.R. 82:2017, BS 5534:2014+A2: 2018 and any new code of practices in the future. Condron Concrete Roof Tiles are manufactured in compliance with E.N. 490:2011+A1: 2017 Concrete Roofing Tiles & Fittings.

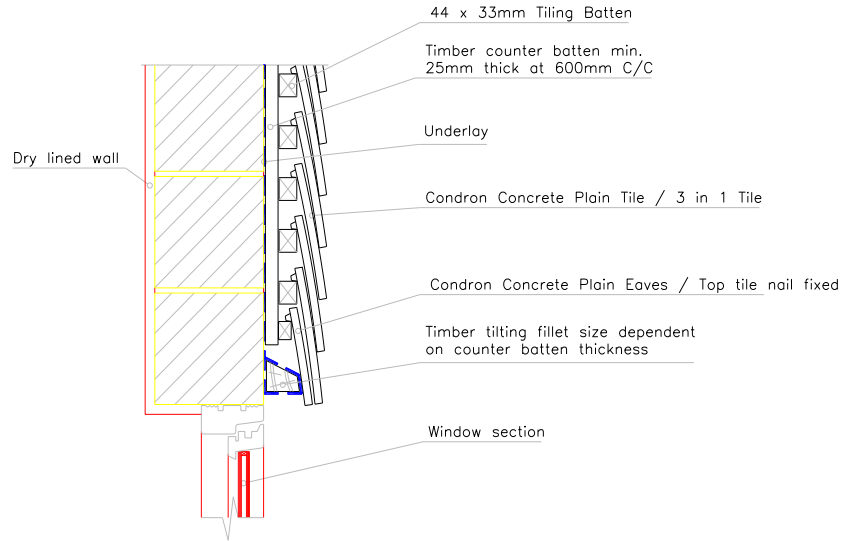

Window Head Detail (Plain Tile / 3 in 1 Tile)

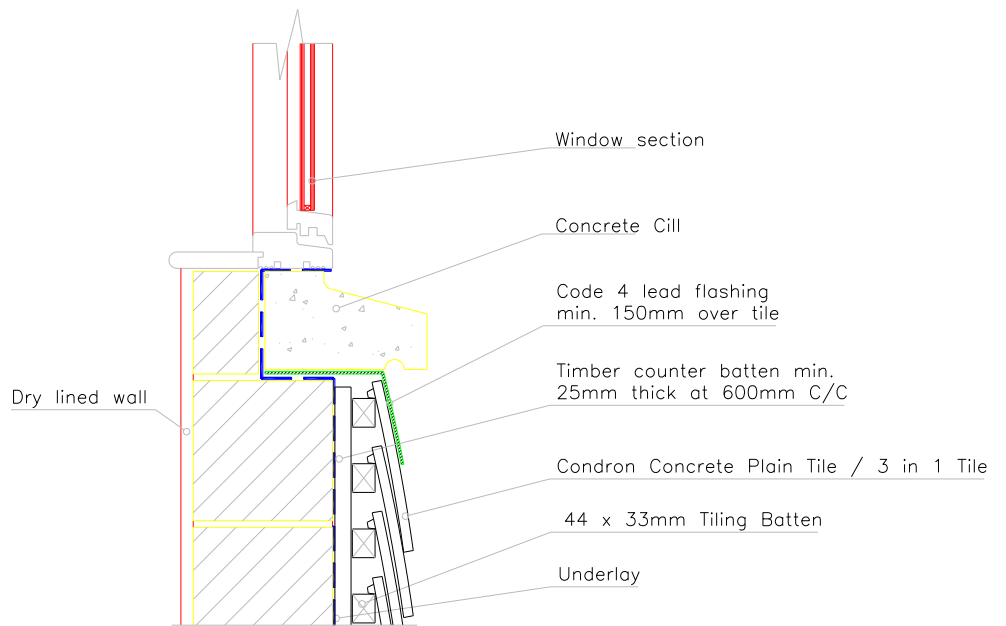

Window Cill Detail (Plain Tile / 3 in 1 Tile)

NOTE: Reference should be made to Code of Practice for Slating and Tiling, S.R. 82:2017, BS 5534:2014+A2: 2018 and any new code of practices in the future. Condron Concrete Roof Tiles are manufactured in compliance with E.N. 490:2011+A1: 2017 Concrete Roofing Tiles & Fittings.

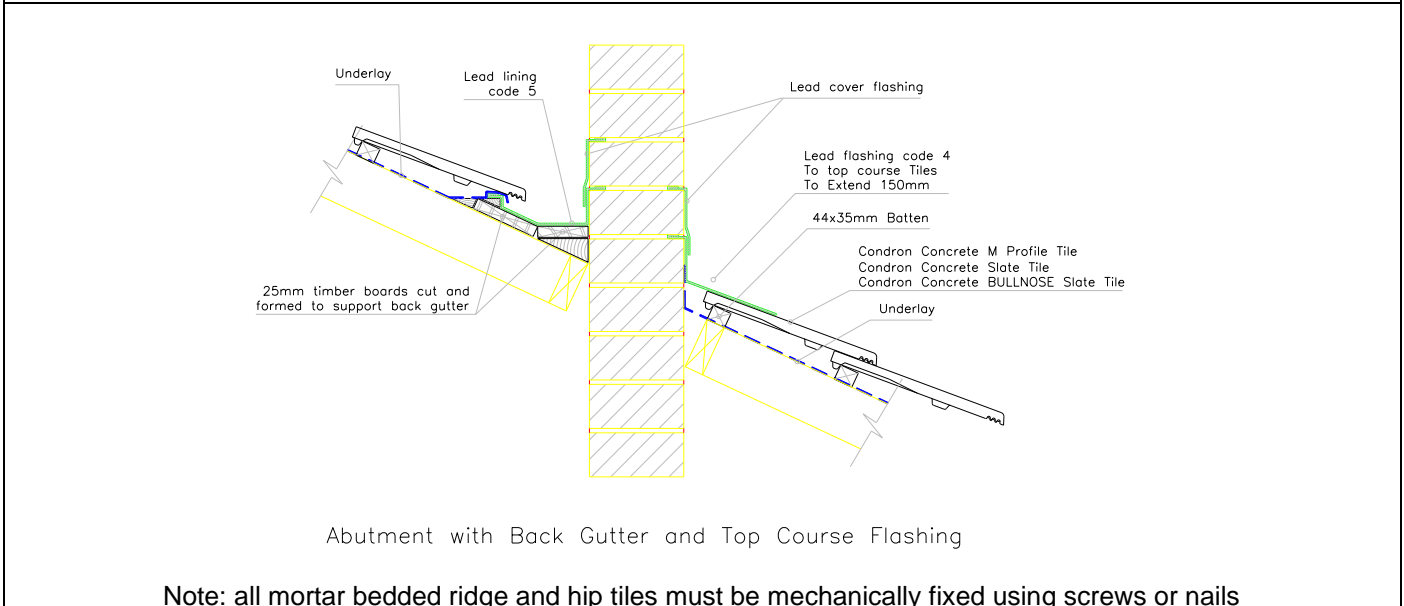
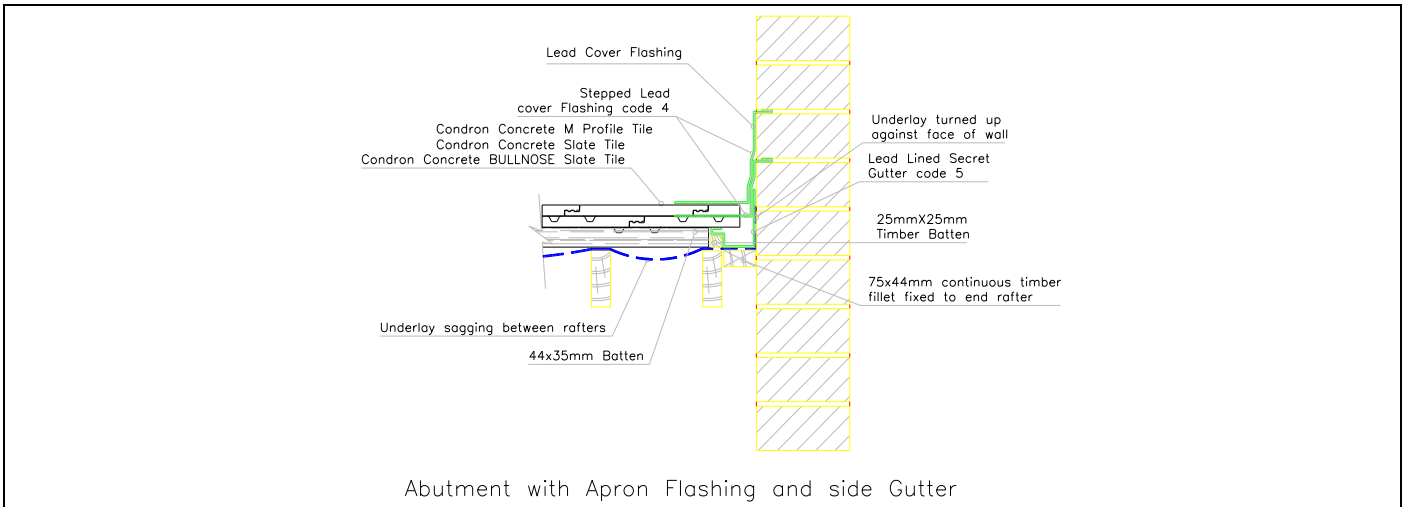

Note: all mortar bedded ridge and hip tiles must be mechanically fixed using screws or nails

NOTE: Reference should be made to Code of Practice for Slating and Tiling, S.R. 82:2017, BS 5534:2014+A2: 2018 and any new code of practices in the future. Condrón Concrete Roof Tiles are manufactured in compliance with E.N. 490:2011+A1: 2017 Concrete Roofing Tiles & Fittings.

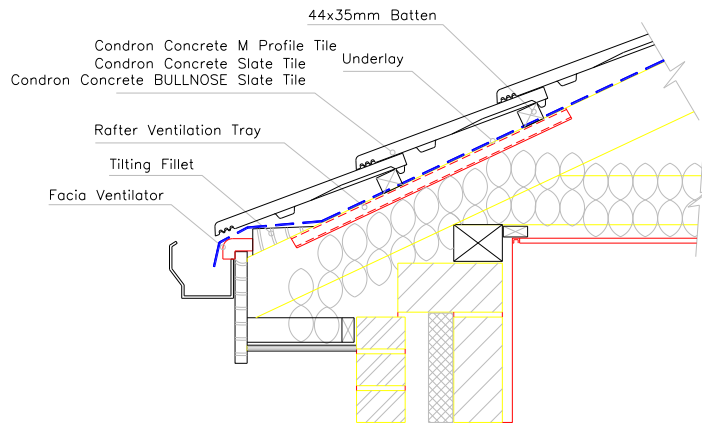

Eaves Ventilation (M Profile Tile/ Slate Tile /Bullnose Tile)

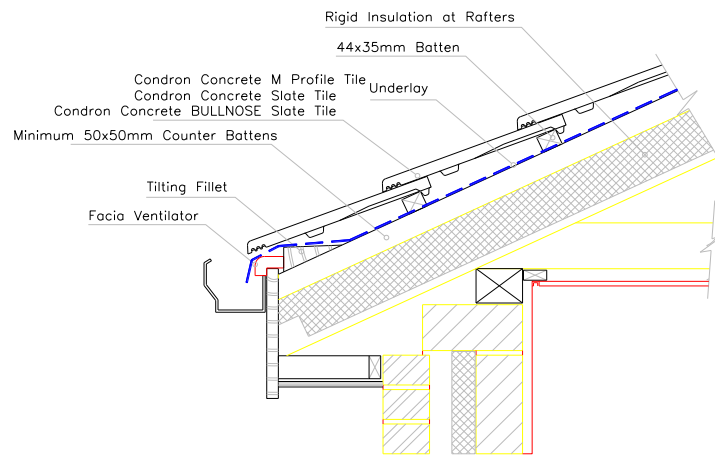

Eave Ventilation Insulation at Rafter Level

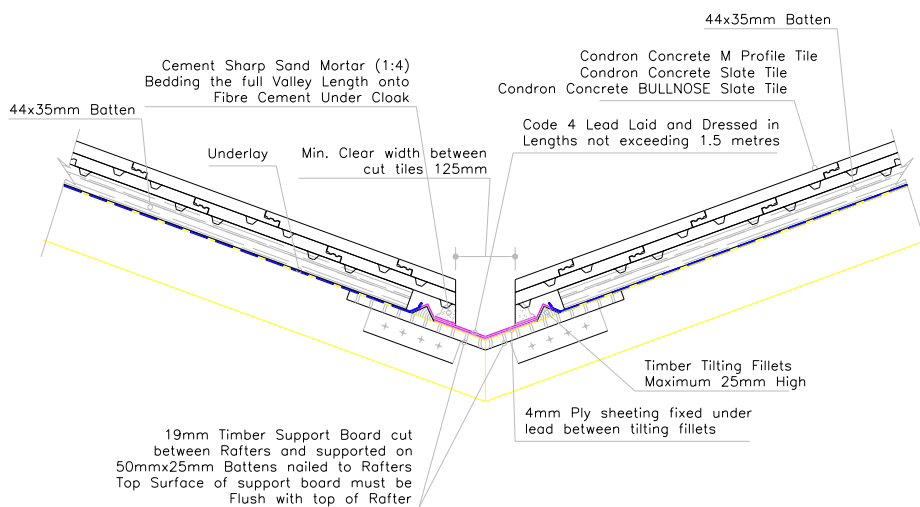

Lead Valley

NOTE: Reference should be made to Code of Practice for Slating and Tiling, S.R. 82:2017, BS 5534:2014+A2: 2018 and any new code of practices in the future. Condron Concrete Roof Tiles are manufactured in compliance with E.N. 490:2011+A1: 2017 Concrete Roofing Tiles & Fittings.

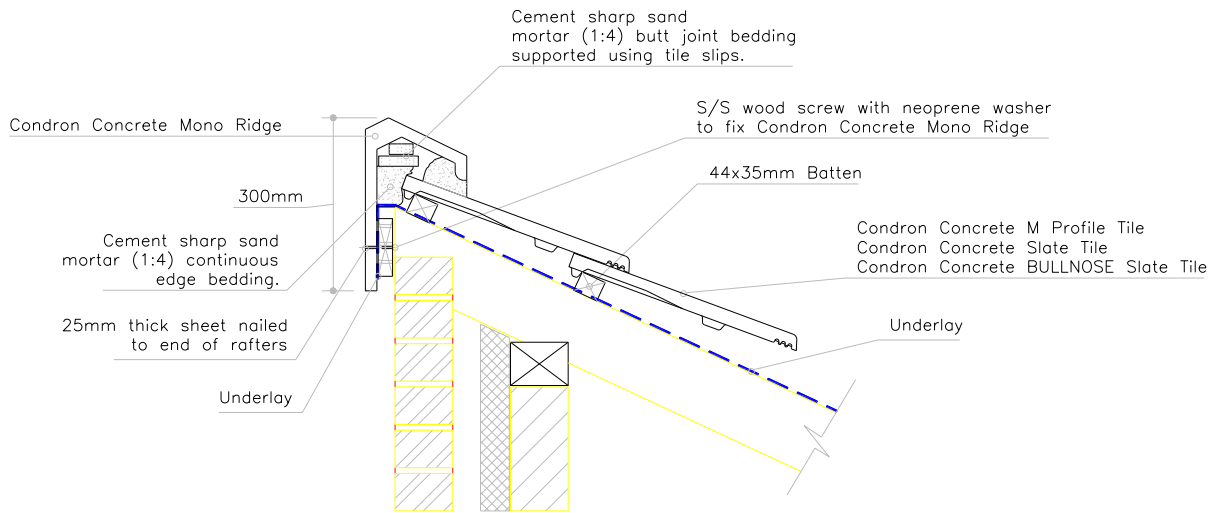

Mortar Bedded Mono Ridge (M Profile Tile/ Slate Tile /Bullnose Tile)

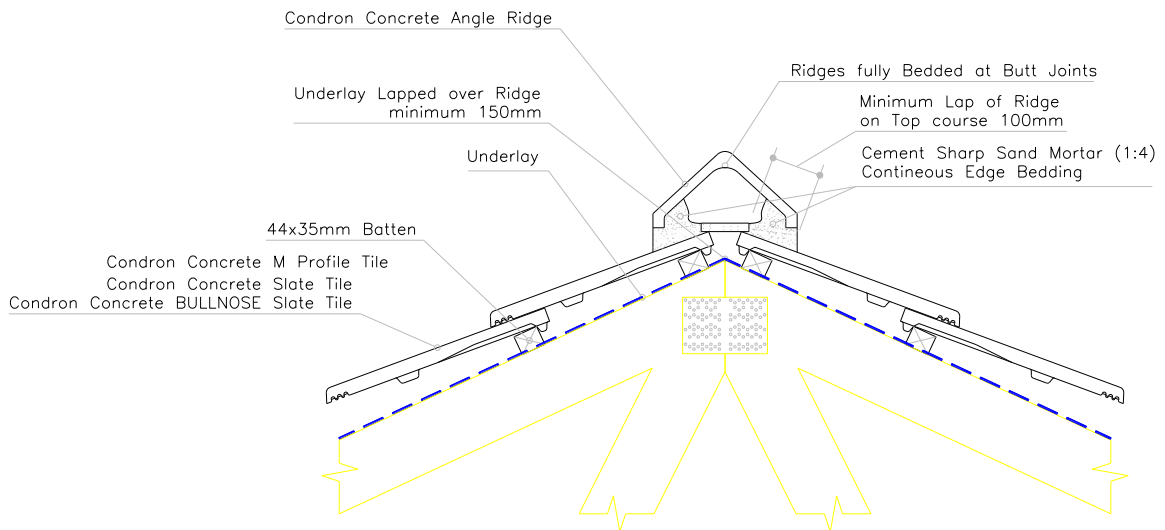

Mortar Bedded Ridge

Note: all mortar bedded ridge and hip tiles must be mechanically fixed using screws or nails

NOTE: Reference should be made to Code of Practice for Slating and Tiling, S.R. 82:2017, BS 5534:2014+A2: 2018 and any new code of practices in the future. Condron Concrete Roof Tiles are manufactured in compliance with E.N. 490:2011+A1: 2017 Concrete Roofing Tiles & Fittings.

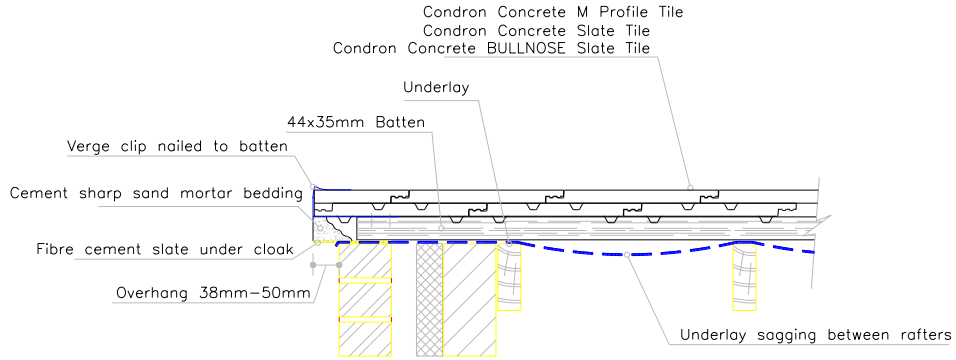

Mortar Bedded Verge

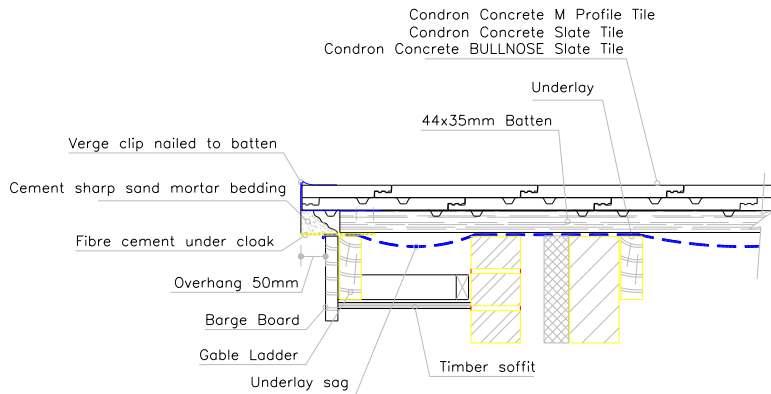

Mortar Bedded Verge with Barge Over-Hang

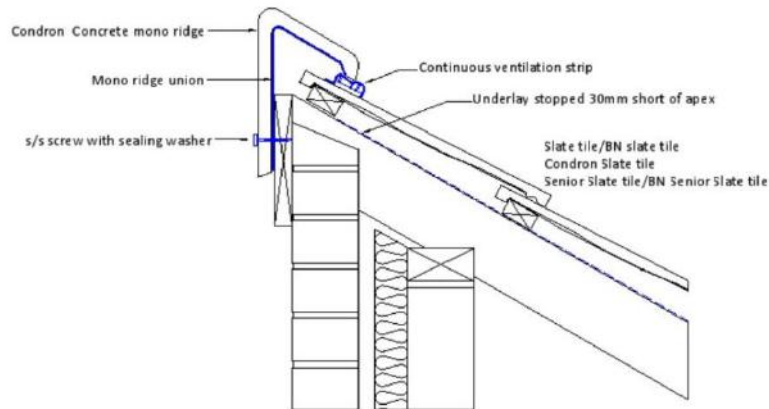

Dry fix mono ridge detail with Concrete Senior slate tiles

NOTE: Reference should be made to Code of Practice for Slating and Tiling, S.R. 82:2017, BS 5534:2014+A2: 2018 and any new code of practices in the future. Condron Concrete Roof Tiles are manufactured in compliance with E.N. 490:2011+A1: 2017 Concrete Roofing Tiles & Fittings.

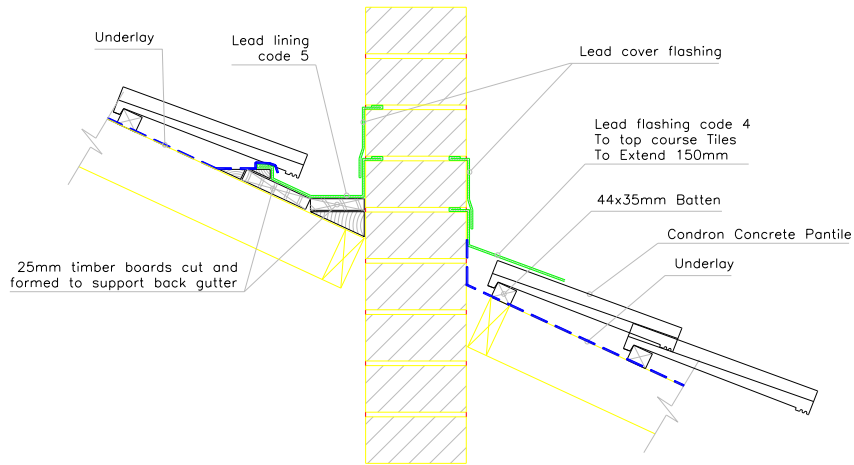

Abutment with Back Gutter and Top Course Flashing

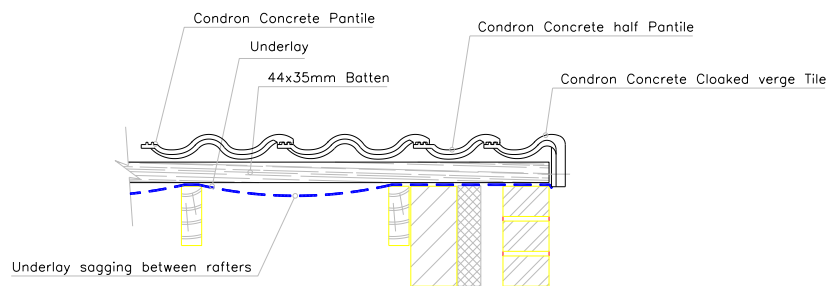

Cloaked Verge Right Hand

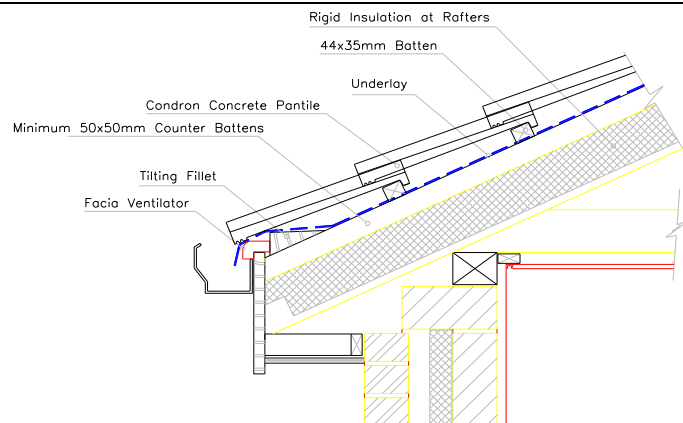

Eave Ventilation Insulation at Rafter Level

NOTE: Reference should be made to Code of Practice for Slating and Tiling, S.R. 82:2017, BS 5534:2014+A2: 2018 and any new code of practices in the future. Condron Concrete Roof Tiles are manufactured in compliance with E.N. 490:2011+A1: 2017 Concrete Roofing Tiles & Fittings.

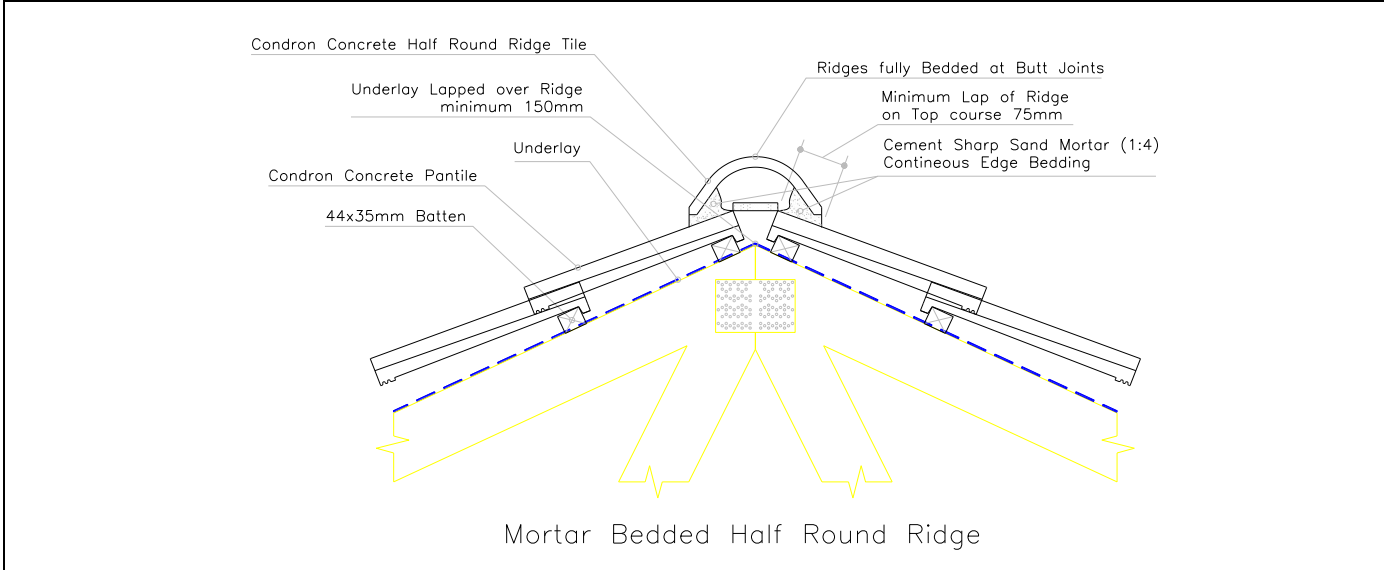
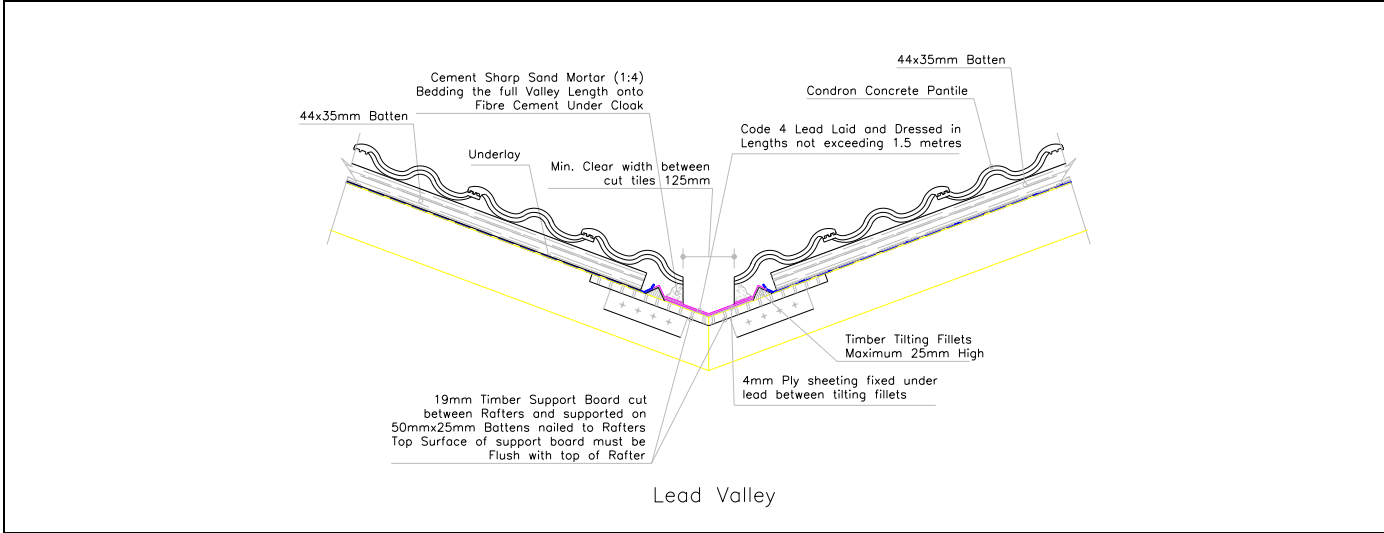
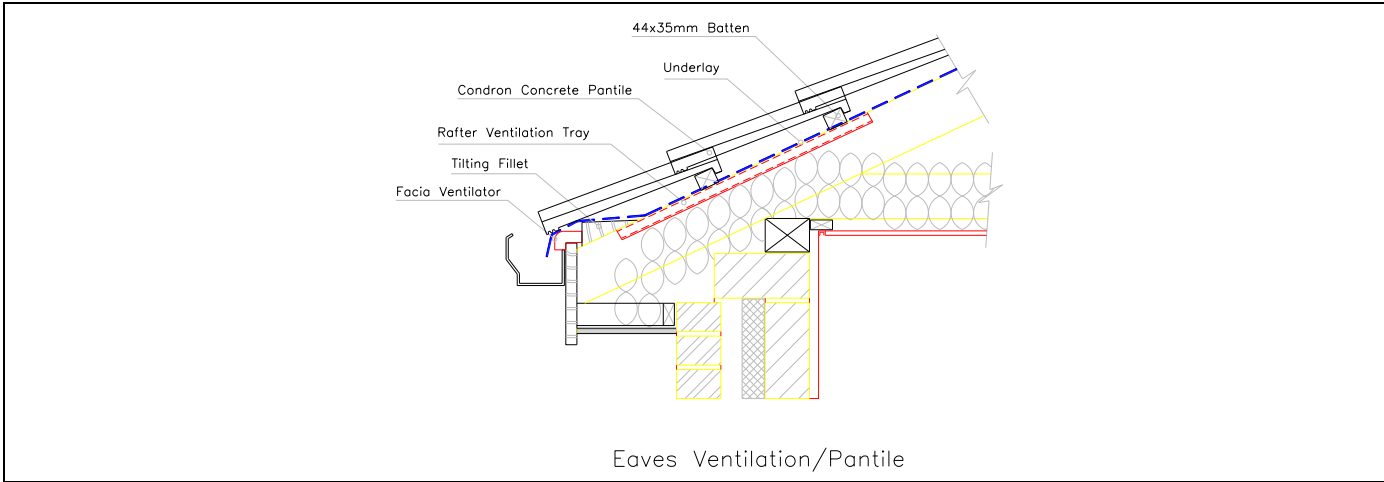

Note: all mortar bedded ridge and hip tiles must be mechanically fixed using screws or nails

NOTE: Reference should be made to Code of Practice for Slating and Tiling, S.R. 82:2017, BS 5534:2014+A2: 2018 and any new code of practices in the future. Condron Concrete Roof Tiles are manufactured in compliance with E.N. 490:2011+A1: 2017 Concrete Roofing Tiles & Fittings.

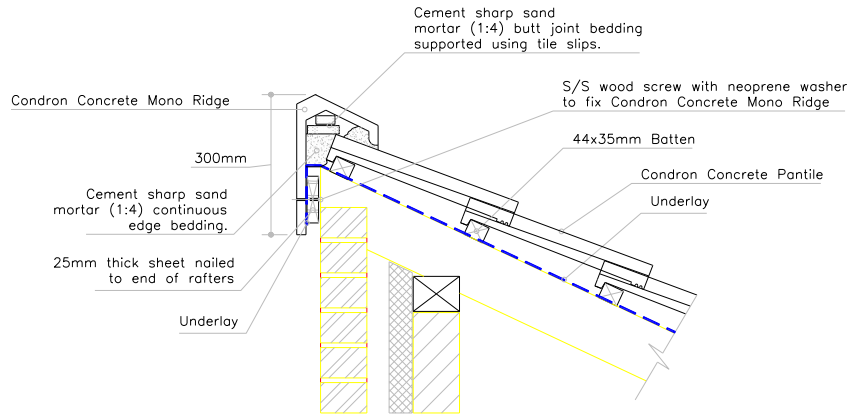

Mortar Bedded Mono Ridge/Pantile

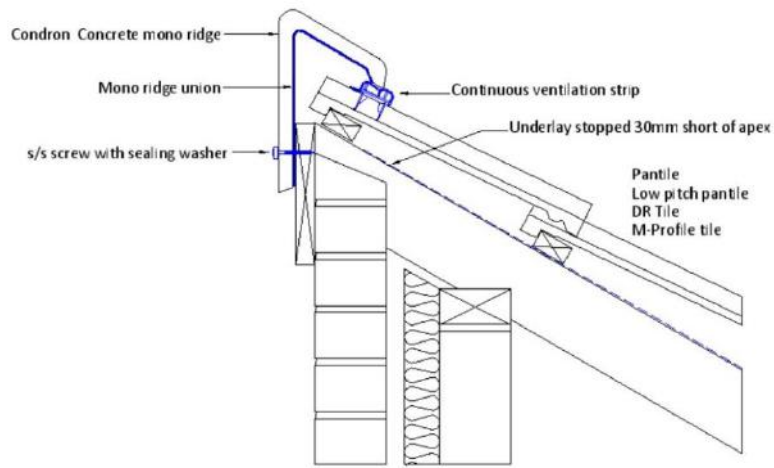

Dry fix mono ridge detail with Concrete Pantiles

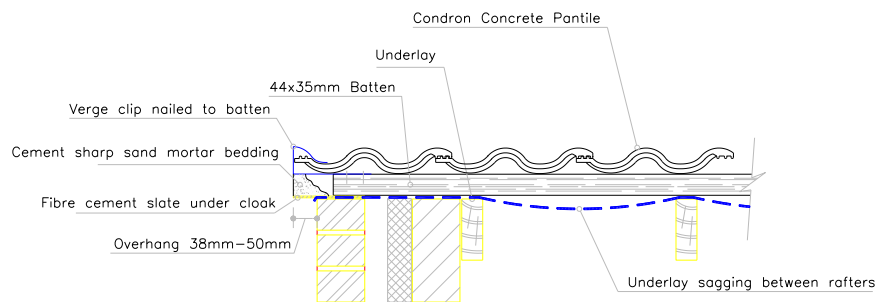

Mortar Bedded Verge

NOTE: Reference should be made to Code of Practice for Slating and Tiling, S.R. 82:2017, BS 5534:2014+A2: 2018 and any new code of practices in the future. Condron Concrete Roof Tiles are manufactured in compliance with E.N. 490:2011+A1: 2017 Concrete Roofing Tiles & Fittings.

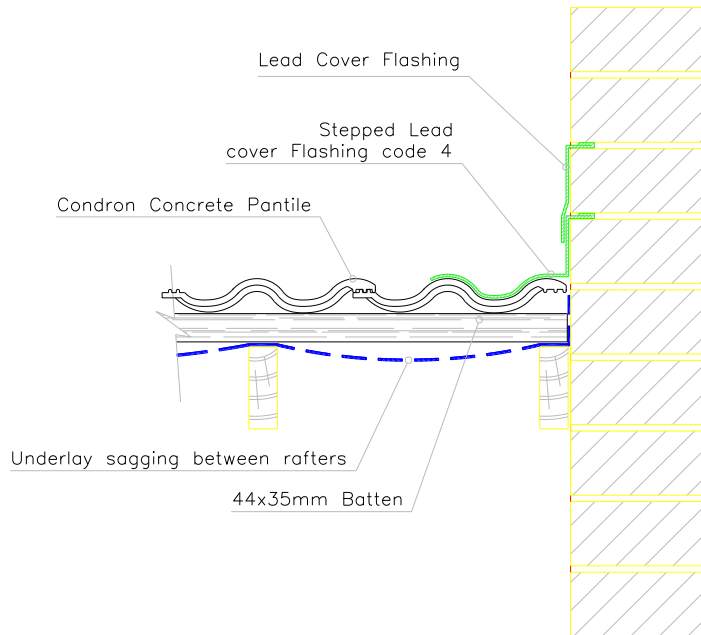

Side Abutment Stepped Lead Cover Flashing/Pantile

NOTE: Where this detail shows counter battens the same detail will apply if counter battens are not used

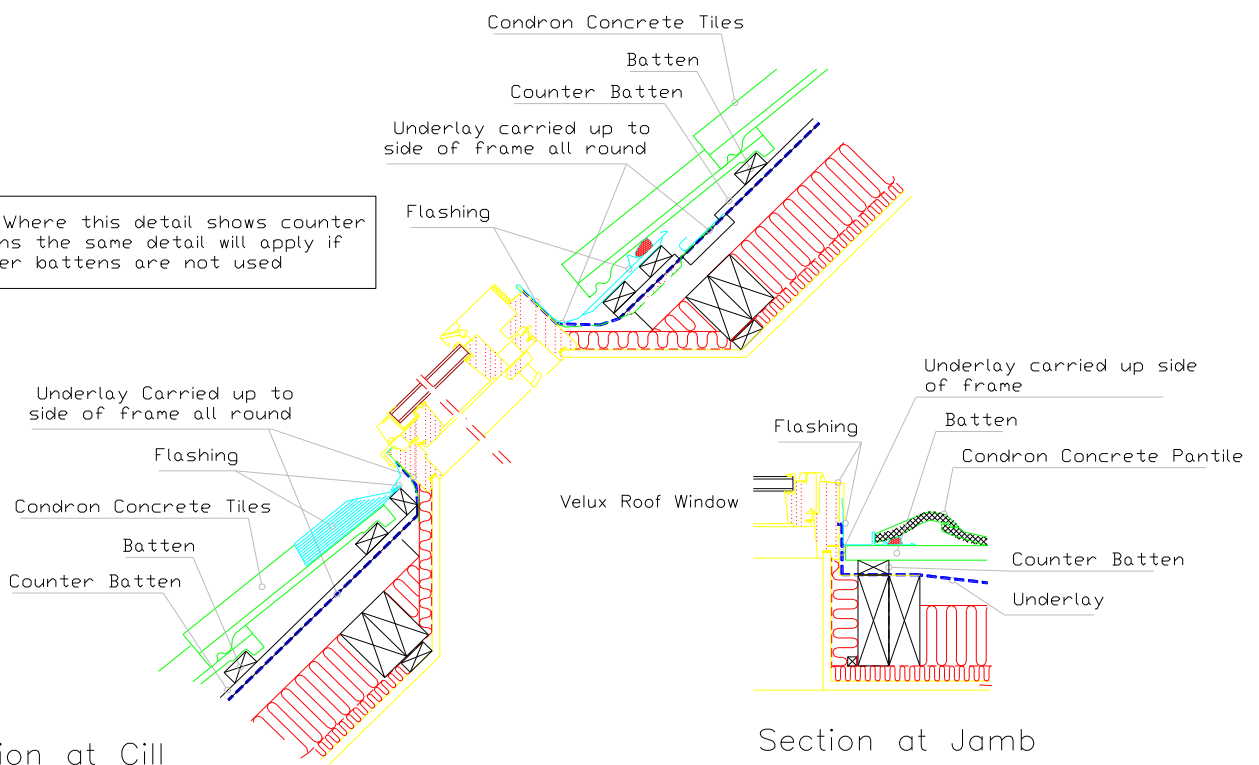

NOTE: Reference should be made to Code of Practice for Slating and Tiling, S.R. 82:2017, BS 5534:2014+A2: 2018 and any new code of practices in the future. Condron Concrete Roof Tiles are manufactured in compliance with E.N. 490:2011+A1: 2017 Concrete Roofing Tiles & Fittings

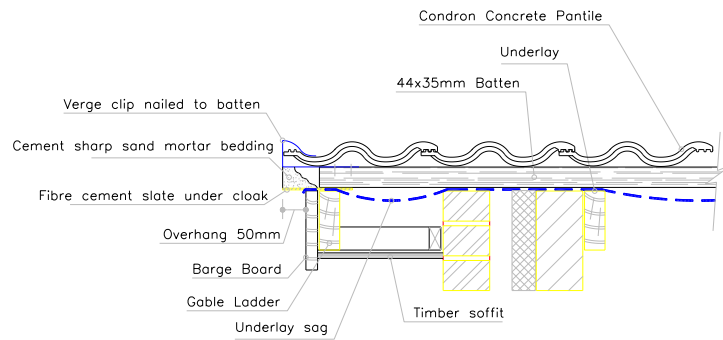

Mortar Bedded Verge with Barge Over-Hang



Condron Concrete Works

CONDRON CONCRETE WORKS IS A TRADENAME FOR CONDRON CONCRETE LTD.

ARDEN ROAD, TULLAMORE, CO. OFFALY, IRELAND.

Fixing Accessories

2-in-1 Batten Clip

Slate Tile
Bullnose Slate Tile
Condron Slate
Senior Slate
Senior Bullnose Slate



Fixes straight into the batten without nails

BATTEN CLIPS

Pantile



75 mm nails with batten clips

Concrete Slate Tile
Concrete Bullnose Slate Tile

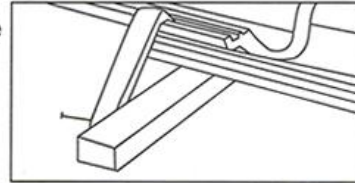

EAVE CLIPS

Concrete Slate Tile
Concrete Bullnose Slate Tile



Pantile

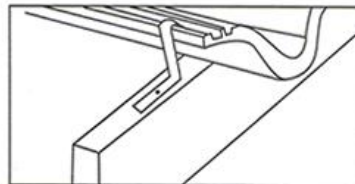

VERGE CLIPS

Concrete Slate Tile
Concrete Bullnose Slate Tile

Right Hand



Left Hand

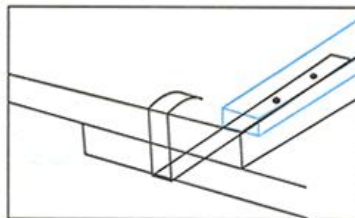

Pantile

Left Hand



Right Hand

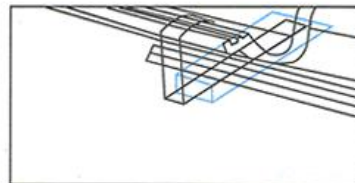



Condron Concrete Works

CONDRON CONCRETE WORKS IS A TRADENAME FOR CONDRON CONCRETE LTD.

ARDEN ROAD, TULLAMORE, CO. OFFALY, IRELAND.

Hip Clip

Stainless Steel Cut Tile Retaining Clip with approx. 350mm wire tail.
Clip hammers to the top edge of the tile and the wire secured around fixing into hip rafter or suitable other fixing point.

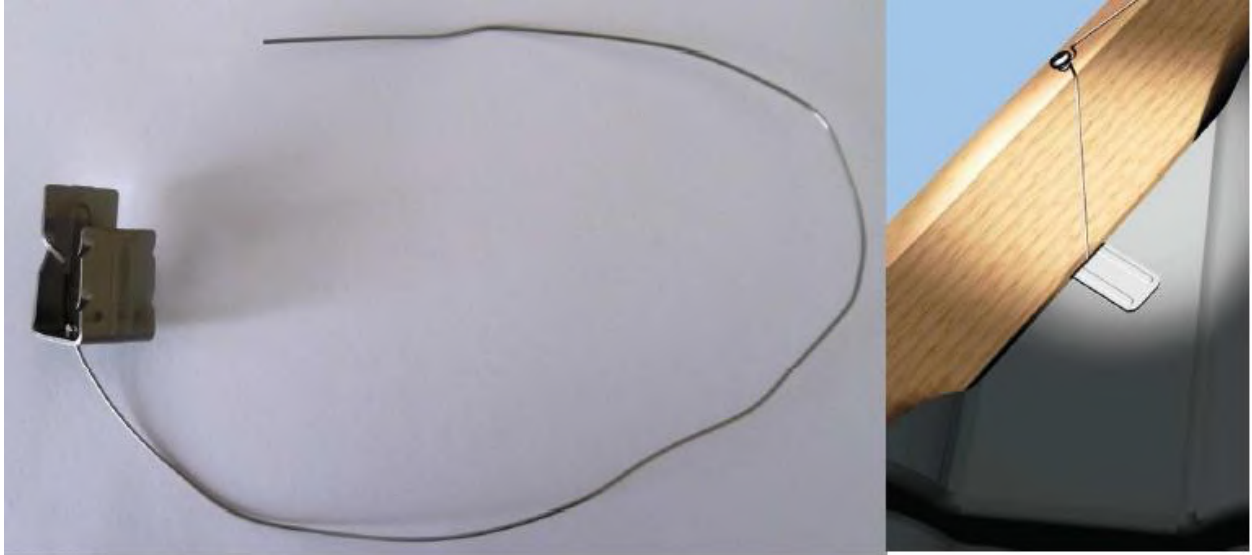

Aluminium Hip Clips for nailing to timber or wrapping around the head of the tile as shown below.

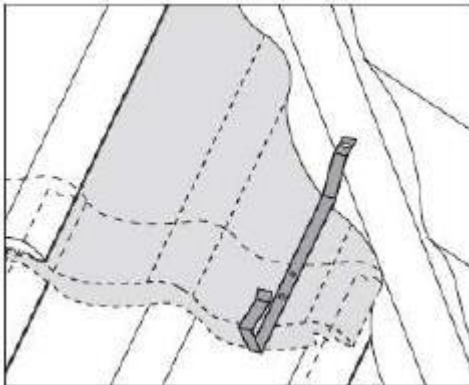

Hip Clips can be secured either by nailing into a suitable timber.

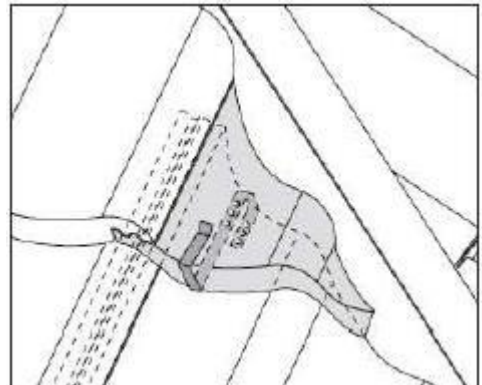

Or by wrapping over the head of the tile below.

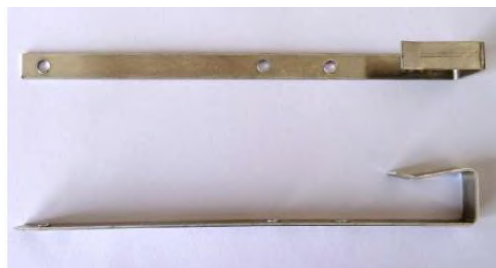

Available for Standard Tiles and Thin Leading Edge Tiles.



Condron Concrete Works

CONDRON CONCRETE WORKS IS A TRADENAME FOR CONDRON CONCRETE LTD.

ARDEN ROAD, TULLAMORE, CO. OFFALY, IRELAND.

Roof Ventilation Recommendations

Ventilation requirements are expressed as being equivalent to the width of a continuous opening per metre run of eaves or ridge. Therefore, a continuous opening of 5mm is equal to 5,000mm²/m, 10mm equals 10,000mm²/m. Ventilation may also be provided by a series of openings corresponding to the required mm per metre.

Duo Pitch Roofs

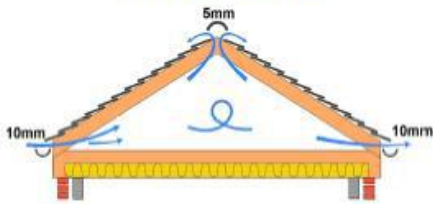

For roof pitches of 15° and above with insulation at ceiling level:

10,000mm²/m at eaves
plus
5,000mm²/m at the ridge, or at high level *
* for duo pitches this can be 2,500mm²/m on either side of the ridge line.

Mono Pitch Roofs

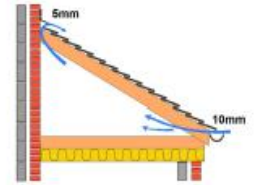

Compartmented Roofs

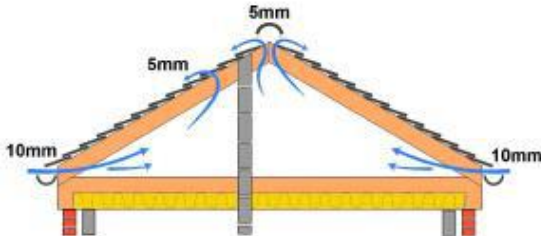

Where a roof space, with insulation at ceiling level, is divided by internal walls, each and every compartment within the roof must be considered individually for the purposes of ventilation at both low and high level.

Roofs with high level insulation

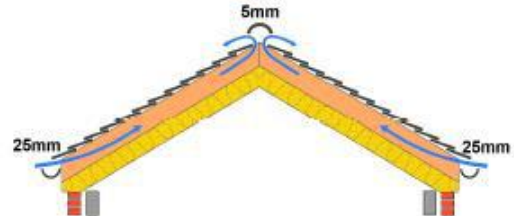

For roof pitches of 10° and above with insulation at rafter level;
25,000mm²/m at eaves
plus
5,000mm²/m at the ridge, or at high level *
N.B. a 50mm gap is required between underlay & insulation.

IV100 Inline Vent



10,000mm² ventilation capacity
Minimum Pitch 22.5°
Suitable for roof space ventilation or for soil vent and for kitchen and bathroom extractors
110mm outlet for senior

LV75 Cowl Vent



7,500mm² ventilation capacity
Minimum Pitch 15°
Suitable for roof space ventilation or for soil vent and for kitchen and bathroom extractors
110mm outlet with fitted adapter.

LV200 Cowl Vent



20,000mm² ventilation capacity
Minimum Pitch 15°
Suitable for roof space ventilation or for mechanical extractors up to 150mm using the optional multi adapter.
For flat

Underlay protector



All vents are supplied with an underlay protector, which when inserted above any opening in the underlay will protect it from water ingress into the roof void.

Quick-Flex Connector



The innovative Quick-Flex connector easily connects the 110mm outlet on the back of the tile vent to other rigid PVC pipes used for soil vent or kitchen and bathroom extractors. The hand tightened compression fitting avoids the need for any tools during installation.

Multi Adapter



The optional multi-adapter is used to connect the LV200 vent to pipes ranging in size from 150 down to 100mm. Simply cut to the required size.



Condron Concrete Works

CONDRON CONCRETE WORKS IS A TRADENAME FOR CONDRON CONCRETE LTD.

ARDEN ROAD, TULLAMORE, CO. OFFALY, IRELAND.

OFV Over Fascia Ventilation 10 & 25mm

To comply with building regulations (Approved Document C2) all newly built properties must have continuous ventilation at eaves level to avoid damp and condensation within the roof void. Inadequate ventilation to the loft will cause structural damage to the roof timbers.

Good loft ventilation is essential to remove moist air from the loft space, and ensures continuous airflow throughout the roofing system, thereby allowing the roof to 'breathe'.

Fitted on the top edge of the fascia board, this gives a clean and unbroken 10mm continuous air gap along the eaves.



10mm Over Fascia Ventilator

SIZE - 1000mm long, 21mm high, (10mm OFV)

MATERIAL - Co-Polymer Polypropylene

PACK SIZE - 60 per box (10mm), 50 per box (25mm)

BENEFITS - Low profile design, lightweight, 4mm integral grill, fixing location holes., Extremely strong, resists the weight of tiles



Eaves Comb Filler

The Eaves Comb Filler (Bird Comb) creates a barrier against birds and large insects. It prevents them entering the void between the underside of **Profiled Tiles** and the underlay on pitched roofs.

Injection moulded from high quality, low density polyethylene. Its flexibility prevents any alignment problems.

Manufactured in 1.0mtr strips, which is effective, quick and easy to fit. Durable and totally resistant to decay.

Installation - Fit on top of the fascia ventilator before the tiles are laid, secure with clout nails. The comb must angle outwards away from the roof. Bed the bottom row of tiles on to the comb.

SIZE - 1000mm long, 55mm deep

MATERIAL - Low density polyethylene

PACK SIZE - 300 per box (supplied in split pack of 100)

BENEFITS - Convenient 1mtr lengths, quick & easy to fit





Condron Concrete Works

CONDRON CONCRETE WORKS IS A TRADENAME FOR CONDRON CONCRETE LTD.

ARDEN ROAD, TULLAMORE, CO. OFFALY, IRELAND.

Eaves Comb Filler

A further development of eaves protection comes in the form of the innovative 'one-piece' eaves protector combined with an integrated over fascia ventilator and bird comb.

The 'one-fix' system is provided by an upstand on the underside of the eaves protector, which sits on the top edge of the fascia board, which is supplied with either a 10mm or 25mm continuous vent. Known as a '2 in 1' System, used with Flat Tiles and Slates.

The provision of a fixed bird comb creates an effective barrier against birds and large insects, which is known as a '3 in 1' System, used with all Profiled tiles.

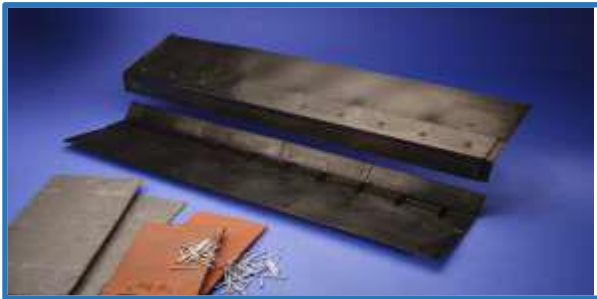

2 in1 Eaves Vent System



3 in1 Eaves Vent System

Installation: New Build - The OVEP is located onto the top of the fascia board, ensuring the stop beads, below the vent, are rested against the front face of the fascia board.

When using a slate or flat tile, where a comb filler is not required, the OVEP is fitted using a minimum 50mm corrosion resistant fixing through the nail/screw ports, ensuring both ends are securely fixed.

Locate the OVEP onto the interlocking section of the previous board, fixing in place. Continue this process along the whole length of the eaves.

Installation: Existing/Retro Fit For refurbishment work, the installation is very similar. Remove or lift the eaves course and make good any damage to the rafters and underlay. The OVEP is fitted in place as above, and the existing underlay relayed on the OVEP. The tiles or slates are the replaced.



3 in1 Eaves Vent System

SIZE - 1000mm long x 200mm cover width

MATERIAL - UV stable polypropylene, 100% re-processed

PACK SIZE - '2 in 1' - 40 per box: '3 in 1' - 20 per box

REGULATIONS - NHBC requirements: Complies with BS5250: 2016

BENEFITS Combined Vent and Felt Support Tray, Strong, Durable, 15 year guarantee, Suitable between 15 & 70 deg. pitch



Condron Concrete Works

CONDRON CONCRETE WORKS IS A TRADENAME FOR CONDRON CONCRETE LTD.

ARDEN ROAD, TULLAMORE, CO. OFFALY, IRELAND.

RPV - Roll Out Rafter Trays

Many of the present continuous type roll panel ventilators are susceptible to collapse when installed due to their manufacturing method, box-like shape and poor design characteristics. The RVP Roll Panel Ventilator has been **designed with better rigidity**, to avoid collapsing when installed over the insulation.

The **robust sinusoidal shape of the ribs** provides additional strength and ensures that when fitted over the wall plate, the ventilation to the roof space remains unobstructed.

The **new widths (600mm, 800mm)** also ensure that when fitted with the new higher levels of insulation, the ends of the ventilators are not blocked.

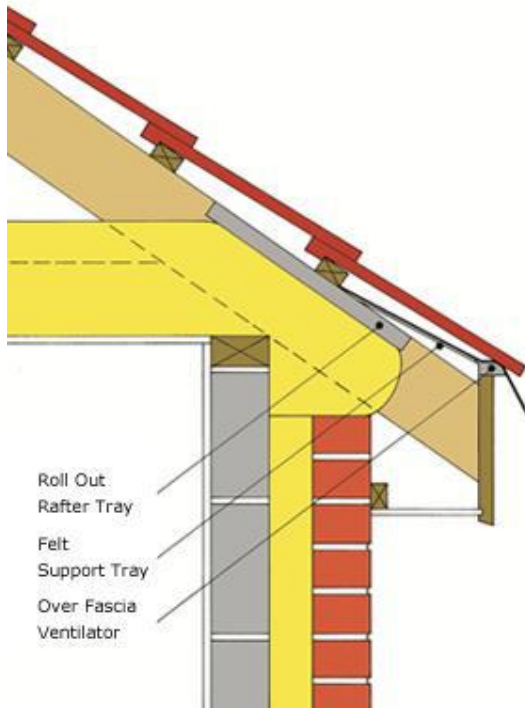
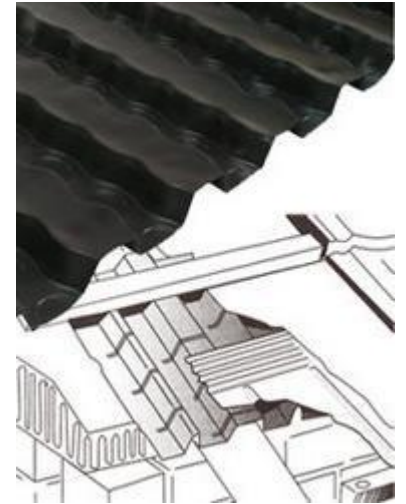

The Roll Out Trays will

provide a clear ventilation channel above the loft insulation and provides continuous ventilation when installed along the entire length of the eaves.

Installation: The Roll Out rafter trays are positioned over the rafters, and are designed to fit rafter centres of 400mm, 450mm and 600mm.

Once in position, they will provide a clear ventilation channel over the roof insulation and fixed into the rafters with corrosion resistant fixings.

The Roll Out Trays are an effective way of preventing the loft insulation from being pushed to the underside of the roofing felt, which then maintains a clear ventilation path into the roof void from the eaves

Range of widths available from stock: - 300mm, 400mm, 600mm, 800mm

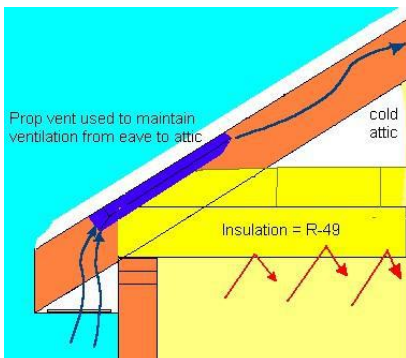

Roll Out Rafter Tray - Fitting Detail

WIDTH SIZE	300mm, 400mm, 600mm, 800mm,
LENGTH	6mtr Roll
PACK SIZE	10 rolls per Box
MATERIAL	Black PVC
BENEFITS	Universal Rafter Fitting, Lightweight, Durable, Reduces the risk of cold bridging



Ventilation – LV75 Vent Tile – Pantile/DR Tile

Application

The LV75 cowl vent is a discreet ventilation solution and suitable as a ventilation outlet from rooms such as kitchens, bathrooms or a stack pipe.

Please refer to national standards.

- For pitched roofs 15° – 45°
- 7,500 mm² ventilation area
- Can be manufactured for any profile

Design

The LV75 design diverts rainwater around the vent. It has a built-in protective grille to keep out insects and drifting snow. The vent is supplied installed on a base plate shaped to fit the roof tile profile 100%. It is easily installed with the rest of the roofing material and always following the roof pitch, the vent presents a nicely integrated solution.

The FS4 adapter, supplied as a click-on addition, allows for connection of a Flexi-pipe and is fixed at the factory.

The vent is supplied complete with an underlay protector to protect the opening in the roof underlay.

Colour and Surface

Special coloured, glossy or structured with sand or granules the vents can be supplied with a 100% colour and surface match individually adjusted to each roofing material.

Materials

Both the Vent and adapter are manufactured from HIPS (High Impact Polystyrene).

Handling

Keep in the original packaging during transport.

Do not wrap and expose to heavy loads during transport.

Remove plastic bag before placing in sunlight.



Accessories





Ventilation – INV100 Inline Vent – 3 in 1 Tile

Application

The INV100 vent is camouflaged to look like the original roofing material, which makes it almost invisible and particularly suitable for flat roofing profiles. It is suitable as ventilation outlet from living quarters like kitchen, bathroom and laundry room.

Please refer to national standards.

- For pitched roofs min. 40°
- 10,000 mm² ventilation area
- Can be manufactured for shingle profiles only

Design

The INV100 vent is designed with a built-in water stop concealed under the roof, which diverts rainwater safely back onto the roof surface. A protective grille keeps out insects and drifting snow. Easily installed with the rest of the roof the vent presents a very discreet ventilation solution.

The FS7 and P9 adapters allow for connection of Tubivent.

Colour and Surface

Special coloured, glossy or structured with sand or granules the vents can be supplied with a 100% colour and surface match individually adjusted to each shingle type.

Materials

Vent and adapters are manufactured from HIPS (High Impact Polystyrene).

Tubivent is manufactured from PP (Polypropylene).

Handling

Keep in original packaging during transport. Do not wrap and expose to heavy load during transport.

Remove plastic bag before placing in sun.



Accessories

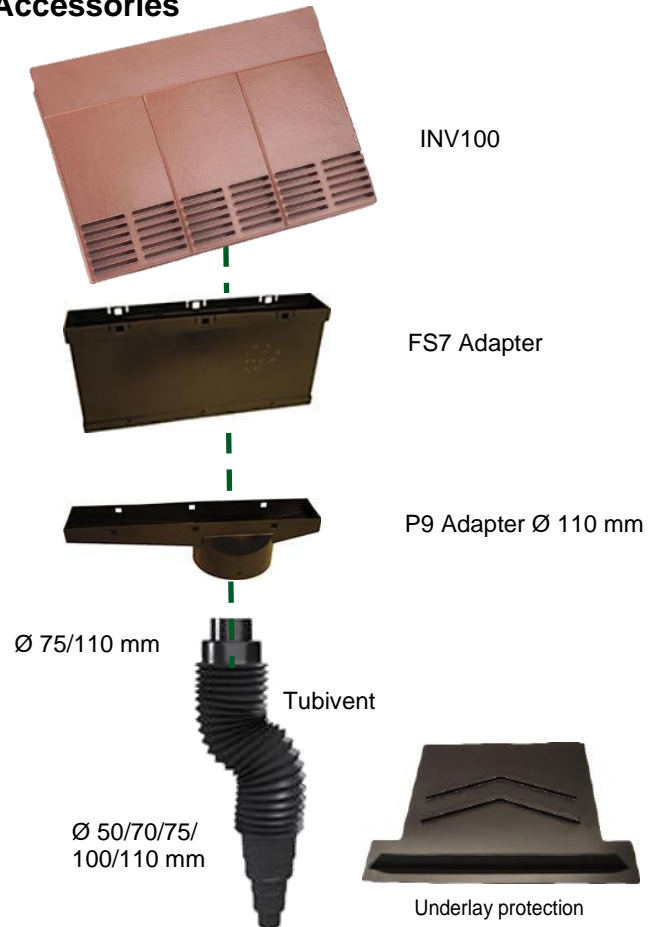



Ventilation – IV100 Inline Vent – Plain Tile

Application

The integrated vent IV100 is an absolutely discreet solution for ventilation of the roof space and batten cavity, or as a sanitary vent.

Please refer to national standards.

- For pitched roofs
- 10,000 mm² ventilation area
- Can be manufactured for any profile

Note: min. 22.5° pitch but depending on profile.

Design

The IV100 vent is designed to be as efficient and discreet as possible. It has a built in water stop, which diverts rainwater safely back onto the roof surface. A protective grille keeps out insects and drifting snow. The vent is supplied installed in a base plate shaped to fit the roof profile 100%.

Easily installed with the rest of the roofing material the vent presents a very discreet ventilation solution.

The vent is supplied complete with an underlay protector to protect the opening in the roof underlay.

Colour and Surface

Special coloured, glossy or structured with sand or granules the vents can be supplied with a 100% colour and surface match individually adjusted to each roofing material.

Materials

Both the Vent and adapter are manufactured from HIPS (High Impact Polystyrene).

Handling

Keep in the original packaging during transport.

Do not wrap and expose to heavy loads during transport.

Remove plastic bag before placing in sunlight.



Accessories

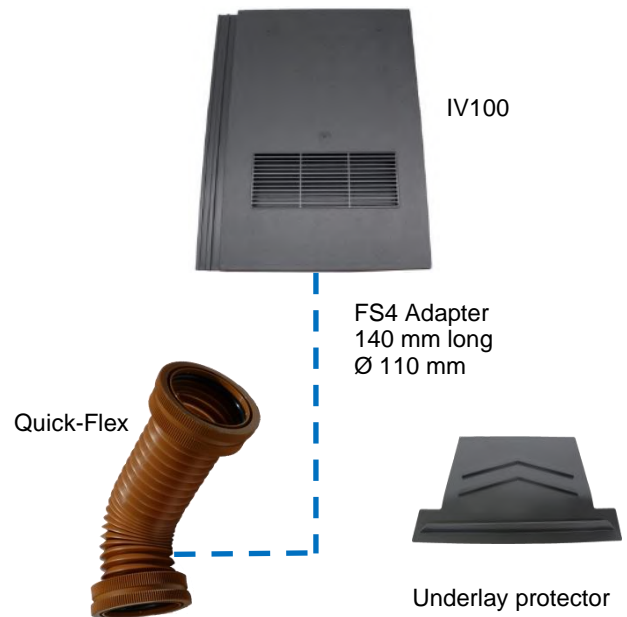



Ventilation – IV100 Inline Vent – Pantile/DR Tile

Application

The integrated vent IV100 is an absolutely discreet solution as outlet of air from living quarters like kitchen, bathroom, and laundry room or as stack pipe.

Please refer to national standards.

- For pitched roofs
- 10,000 mm² ventilation area
- Can be manufactured for any profile

Note:

Slate: min. 25° pitch

Clay and concrete: min. 22.5° pitch but depending on profile.

Design

The IV100 vent is designed to be as efficient and discreet as possible. It has a built in water stop concealed under the roof, which diverts rainwater safely back onto the roof surface. A protective grille keeps out insects and drifting snow. The vent is supplied installed in a base plate shaped to fit the roof profile 100%.

Easily installed with the rest of the roofing material, the vent presents a very discreet ventilation solution.

Colour and Surface

Special coloured, glossy or structured with sand or granules the vents can be supplied with a 100% colour and surface match individually adjusted to each roofing material.

Materials

Vent and adapter are manufactured from HIPS (High Impact Polystyrene).

The Tubivent is manufactured from PP (Polypropylene).

Handling

Keep in original packaging during transport. Do not wrap and expose to heavy load during transport.

Remove plastic bag before placing in sunlight.



Accessories

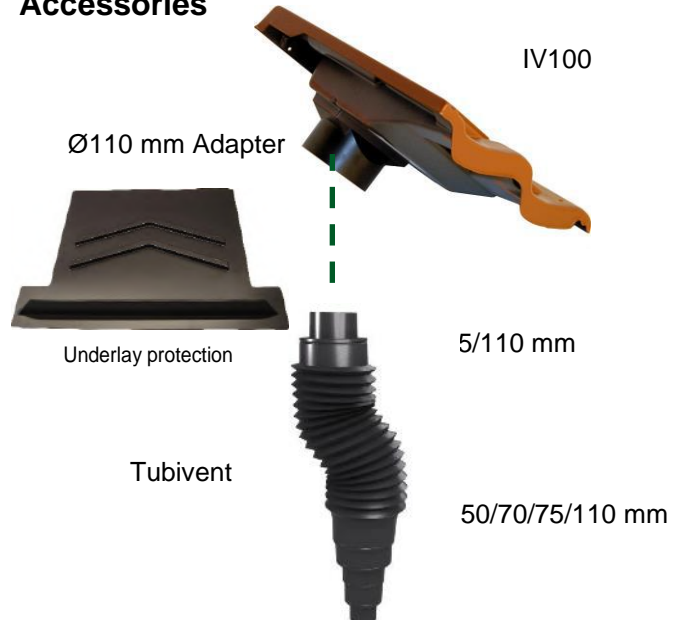



LV200 Vent Tile – Pantile/DR Tile

Application

The cowl vent LV200 is a discreet ventilation solution and ideal outlet for air from living quarters like kitchen, bathroom, tumbler, laundry room and as stack pipe.

LV200 can also be used for mechanical ventilation.

Please refer to national standards.

- For pitched roofs 15° – 45°
- 20,000 mm² ventilation area
- Can be manufactured for any profile

Design

The LV200 vent is designed especially for humid climates where requirements for ventilation are even more essential. Rain is diverted around the vent and a built in protective grille keeps out insects and drifting snow. The vent is supplied installed on a base plate shaped to fit the roof profile 100%. Easily installed with the rest of the roofing material and always following the roof pitch, the vent presents a nicely integrated solution.

The Ø 160mm adapter allows for connection of Multiadapter and Tubivent.

Colour and Surface

Special coloured, glossy or structured with sand or granules the vents can be supplied with a 100% colour and surface match individually adjusted to each roofing material.

Materials

Vent and adapters are manufactured from HIPS (High Impact Polystyrene).

The Tubivent is manufactured from PE (Polypropylene).

Handling

Keep in original packaging during transport. Do not wrap and expose to heavy load during transport.

Remove plastic bag before placing in sunlight.



Accessories





Solar Tube Tile - TT- Plain Tile

Application

Tube Tile is developed specially for leading pipes safely through the roof surface e.g. from solar systems.

Please refer to national standards.

- For pitched roofs 15° – 45°
- Can be manufactured for any profile

Design

Available as:

TT-1 – with rubber sleeve, water stop and 2 drain holes. Max. Ø 46 mm pipe. For slates, steel and corrugated sheets.

TT-2 – with rubber sleeve Max. Ø 46 mm pipe. For clay and concrete.

TT-3 – with water stop and 2 drain holes. Max. Ø 90 mm pipe. For slates, steel and corrugated sheets.

TT-4 – cast in one piece.

Max. Ø 90 mm pipe. For clay and concrete.

TT-5 – with rubber sleeves, water stop and 2 drain holes. 2 pipes max. Ø 27 mm. For slates, steel and corrugated sheets.

TT-6 – with rubber sleeves. 2 pipes max. Ø 27 mm. For clay and concrete.

The tube tile is supplied installed on a base plate shaped to match the roof profile 100%. Easily installed with the rest of the roof and discreetly integrated in the roof surface.

Colour and Surface

Special coloured, glossy or structured with sand or granules the vents can be supplied with a 100% colour and surface match individually adjusted to each roofing material.

Materials

Tube Tile is manufactured from HIPS (High Impact Polystyrene).

Handling

Keep in original packaging during transport. Do not wrap and expose to heavy load during transport.

Remove plastic bag before placing in sunlight.





Dry-Fix Ridge System Fitting Instructions

Carton Contents

- 1 No 300mm x 5 metre Ventilated Ridge Roll
Net free ventilation area of roll = 20,000mm²/m
- 10 No Ridge to Ridge Seals
- 20 No 110mm Stainless Steel screwnails
with fitted neoprene washers
- 10 No Ridge tile connector plates

1. Lay the underlay and set back 30mm from ridge apex at each side. Batten the roof in the normal manner, but do not fix the top tiling batten at this stage. Ensure that the top batten is as close to the ridge batten as the tile nibs will allow. Install a ridge batten, using a combination of tiling battens to achieve the correct height. (See table overleaf)

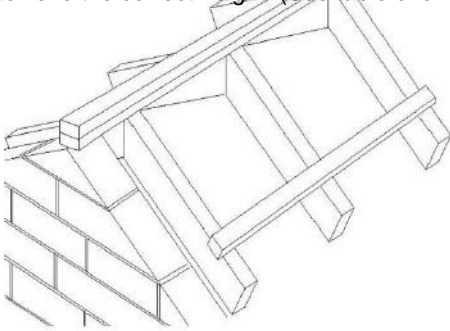

2. Lay and fix the top courses of tiles in the normal way, including all dry verge or mortar bedded verge tiles/slates. Ensure that all fixing of tiles/slates is in accordance with fixing recommendations.

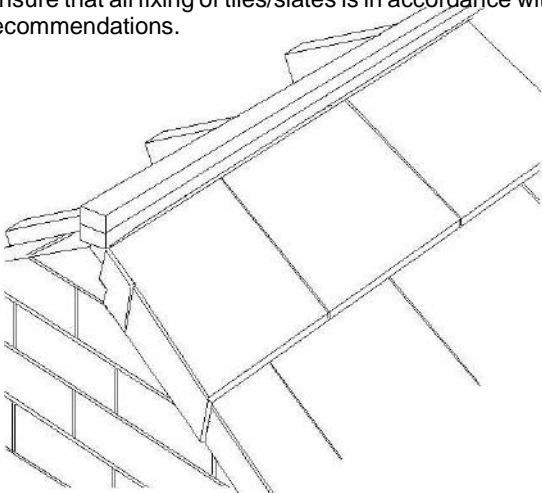

3. Before installing the ridge roll, make sure that the tiles/slates are dry and free from dust and any other surface contamination which could prevent the butyl from sticking to the tiles/slates

4. Roll out the ridge roll along the centre line of the ridge batten and secure with staples or felt nails. Peel off the protective paper strip from the butyl tapes on either side of the roll and press down on to the tiles/slates, ensuring a continuous surface contact.

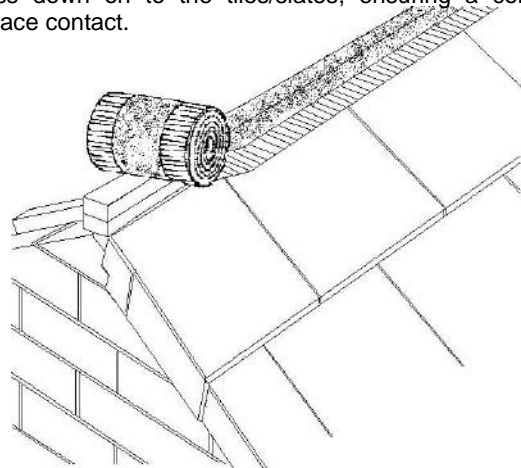

5. Position a ridge to ridge seal under the open end of the first ridge tile and then place the next ridge tile over the seal. Place a ridge tile connector plate over the joint, parallel to the ridge line, and push a plastic plug through the hole in the plate and into the ridge to ridge seal. Nail securely through the hole and into the ridge batten, using the screwnails and washers provided. The screwnails can be driven in with a hammer and then finally tightened, or removed, with a screwdriver. Always ensure that the screwnails penetrate the ridge batten by a minimum of 40mm.

Continue fixing in the same way along the entire length of the ridge, cutting the final ridge to fit. Do not attempt to secure cut ridges less than 200mm long. In this case cut the last 2 ridge tiles. Never place cut ridge tiles at the end of the ridge line.

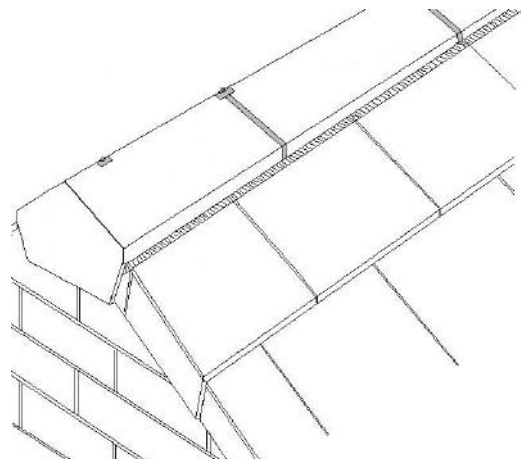



Dry-Fix Ridge System Fitting Instructions

Joining Ridge roll

When joining ridge roll, the overlap must be a minimum of 75mm.

Mortar bedded Verge and end Ridge

Cut the ridge batten back 100mm and the ridge roll 50mm from the flush face of the mortar. Always fit the gable end ridges first and work from gable ends towards abutments. The end ridge is installed onto the verge mortar bedding, flush with the edge of the verge. To secure the end ridge it will be necessary to drill a 5mm diameter hole in the centre of the ridge. Fix securely using a screw nail, washer and plate as provided. Finish the mortar bedding in the usual manner.

Dry Verge and Block-end Ridge

Cut the ridge batten flush with the inside face of the cloaked verge tile (or the outside edge of standard verge tile, where using plastic dry verge systems). Roll the end of the ridge roll down over the face of the dry verge and up under the verge. Always fit the gable end ridges first and work from gable ends towards abutments. The Block-end ridge is installed tight against the finished verge. To secure the Block-end ridge it will be necessary to drill a 5mm diameter hole 100mm in from the outside end. Fix securely using a screw nail, washer and plate as provided.

Abutments

At Abutments the ridge roll should be turned up the wall by 70mm. The ridge tile should be secured as for a mortar bedded verge and a lead saddle should be installed as per the Lead Sheet Associations recommendations.

Junctions

At ridge/hip junctions extend the ridge batten 50mm beyond the apex where the ridge joins the hip rafters. Turn the ridge roll down 75mm over the tiles on the hip end. Install a lead saddle between the ridge roll and the ridge/hip tiles, with a welt along the edges under the ridge and hip tiles. The end ridge and top hip tiles should be neatly mitred, with the end ridge tile drilled as for a mortared verge. Bed the end of the ridge tile before screwing it to the ridge batten with the screw nails, washers and plates provided. Ensure that the screw nail fixing does not penetrate the lead saddle.

T Shaped Buildings

At the ridge intersection of a T shaped building, or where a lower level ridge intersects a roof slope, the ridge construction should not cross over the valley construction. Install a lead saddle onto the valley before laying the tiles/slates. Roll out the ridge roll along the head of the T Shape and stick the aluminium edge to the lead saddle. The ridge roll on the leg of the T shape, or where a low level ridge meets the valley, should be cut back 50mm from the face of the mortar bedding. The end ridge should be fixed as for a mortar bedded verge.

L Shaped Buildings

At the ridge intersection the ridge roll should be overlapped by a minimum of 75mm. Install a lead saddle between the ridge roll and the ridge and hip tiles, with a welt along the edges under the ridge tiles. The end ridges and top hip tile should be neatly mitred, with the end ridge tiles drilled as for a mortared verge. Bed the ends of the ridge tiles with the hip before screwing them to the ridge batten with the screw nails, washers and plates provided. Ensure that the screw nails do not penetrate the lead saddle. Flush off the mortar bedding.

Ridge Batten Height Approx. (mm)

Rafter Pitch	Universal Angle Ridge			
	Condron Slate Tile, The Condron Slate, Senior Slate	Double Lap Slates	Condron Pantile, 'M' Profile	Concrete Plain Tiles, 3 in 1 Tiles
17½°	75	-	125	-
20°	75	75	125	-
22½°	75	50	100	-
25°	75	50	100	-
27½°	75	50	100	-
30°	50	25	100	-
32½°	50	25	100	-
35°	50	25	75	50
37½°	25	25	75	50
40°	25	25	75	25
42½°	25	-	75	25
45°	25	-	75	25
47½°	-	-	50	25



Condron Concrete Works

CONDON CONCRETE WORKS IS A TRADENAME FOR CONDRON CONCRETE LTD.

ARDEN ROAD, TULLAMORE, CO. OFFALY, IRELAND.

Continuous Dry Verge System

Extruded in Black, White Brown and Cherry Oak uPVC

4 Types suitable for use with Slate and most Concrete Roof Tiles

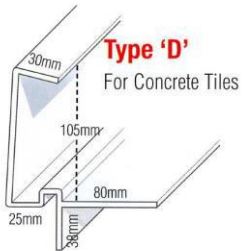

Type 'D'

For Concrete Tiles

Advantages:

Gives complete continuous cover against water penetration for joints between tiles and brickwork or bargeboards at gable ends.

Gives greater security and added strength against wind damage by securing end tiles firmly.

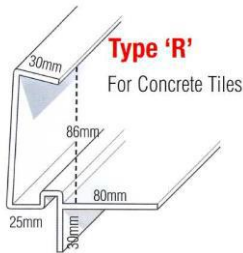

Type 'R'

For Concrete Tiles

- Easily Fitted.
- No undercloak required.
- No mortar joints required.
- No special tools or adhesives.
- Saves time and labour.
- Can be fitted in all weathers.

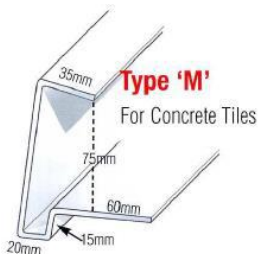

Type 'M'

For Concrete Tiles

- Available in 3 and 4 metre lengths.
- 5 and 6 metre lengths are available on special orders.
- Connector units are available for longer runs.
- Ridge End units complete the apex detail.

Gives a neater and attractive line and finish to gable ends.
No maintenance required.

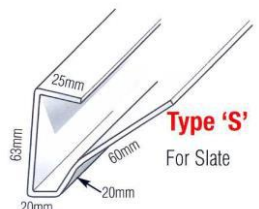

Type 'S'

For Slate

Gives added finish when used with uPVC bargeboards and soffits.



Continuous Dry Verge System –Fitting Instructions

Continuous dry verge system is designed to fit on the gable end of buildings between the underside of the battens and the outer wall of the roof ladder.

- Ensure the gable wall is reasonably level and free from projections.
The roofing felt and battens should be laid across the cavity and the battens finished flush with the outer wall or the outer edge of the bargeboard. Take a length of verge extrusion and plumb cut the upper end. Cut the verge extrusion approximately 150mm longer than the rafter. Remember to allow 10mm between the left and right verge at the ridge for expansion and fitting the ridge cap.
- At the eaves end of the verge, cut a line the length of one tile between the horizontal flange and the fin (see A. on diagram). This allows the verge extrusion to fit on the tiling fillet or felt support tray at the eaves end. The bottom flange of the verge extrusion is then pushed between the wall/roof ladder and the batten. Fix through both the batten and verge into the wall.

OR

- Alternatively, the verge cut and angled appropriately 250mm from the eaves end or near the first batten at the eaves, leave a 5mm gap for expansion. Fit the smaller offcut of the verge with the flange under the batten, ensuring that the length extends approximately 50mm past the line of the fascia into the gutter. Use the angled connector which should be glued over the angled cuts for a neat finish.
- The tiles are then laid in the usual manner ensuring that the verge tiles are inserted fully into the verge extrusion where the top flange will hold them fully.
- At the eaves end the verge should be cut square, flush to the lower tile. The lower fin of the verge may require slight trimming to avoid it interfering with the gutter.
- A small notch may be required in the wall side of the gutter to accommodate the verge channel ensuring that the water drains effectively into the gutter.

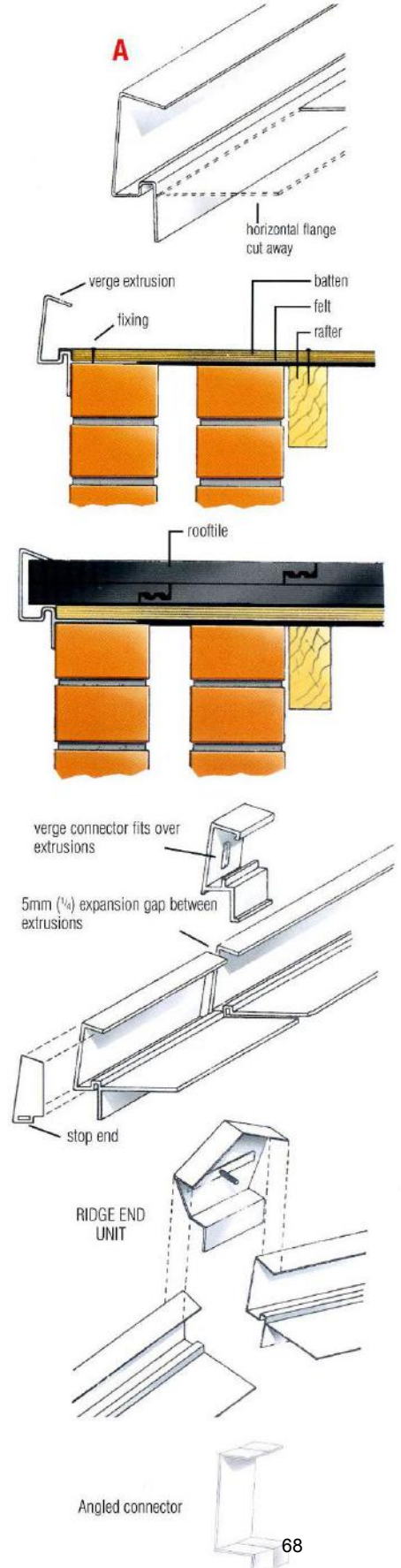



Condron Concrete Works

CONDRON CONCRETE WORKS IS A TRADENAME FOR CONDRON CONCRETE LTD.

ARDEN ROAD, TULLAMORE, CO. OFFALY, IRELAND.

Dry Verge System – Uni-Click



Designed to provide a mortar-free and secure method of fixing concrete interlocking verge tiles. Its neat interlocking design provides a consistent appearance that requires no maintenance.

Product features & benefits

- Mortar free
- All weather fixing
- Secure mechanical fixing avoids wind uplift problems
- Quick and easy to fit – no special tools required
- Available in 4 colours to blend in with roof tiles
- Neat attractive appearance
- Weatherproof and maintenance free
- Unaffected by settlement or differential movement
- UV stable
- Prevents entry of birds and large insects

Area of application

Suitable for:

- Refurbishment or new build on roofs from 12.5° to 90°
- Most makes and profiles of concrete interlocking tiles between 260-350mm batten gauge

Material

Dry Verge unit - UPVC
Eaves Closure - polypropylene
Ridge Closure - polypropylene
Ridge End Cap - polypropylene
Batten End Clip - stainless steel

Colours

Brown, Slate grey, Terracotta, Black

Dimensions

403mm long x 148mm wide x 56mm deep

The new click-system



Installation

Extend the tiling battens 20mm beyond the gable wall or bargeboard and nail a Batten End Clip to the end of every batten. Fix the Eaves Closure to the end of the fascia board or brickwork. Slide the first Uni-Click® Dry Verge unit over the Eaves Closure and the bottom tile. Nail into the tiling batten through the Batten End Clip.

As each successive verge tile is laid, engage a Uni-Click® Dry Verge unit with the one below on the underside of the unit and then click it over the top of the unit below and then slide it up into position nailing through the Batten End Clip into the batten. Insert a Ridge Closure into the last unit, interlocking the combs of each Uni-Click® Dry Verge unit at the apex. Screw fix the Ridge End Cap to the ridge batten.

When installing onto an existing verge the old mortar between the tiles and the undercloak must be removed prior to the verge units being fitted. The tile battens must overhang the gable wall or bargeboard by 20mm and a Batten End Clip nailed to each batten.

If a Batten End Clip is not being used, we recommend that the batten is extended 30mm over the barge board or brickwork and 40mm (minimum) x 3.25mm ring shank nails are used to fix the verge units. Prior to fixing the batten ends must be in good condition with no signs of decay.



Dry Verge System – Uni-Click



Typical verge detail

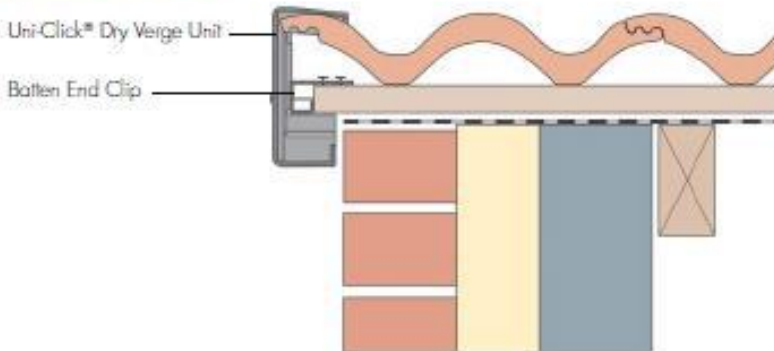

Dimensions

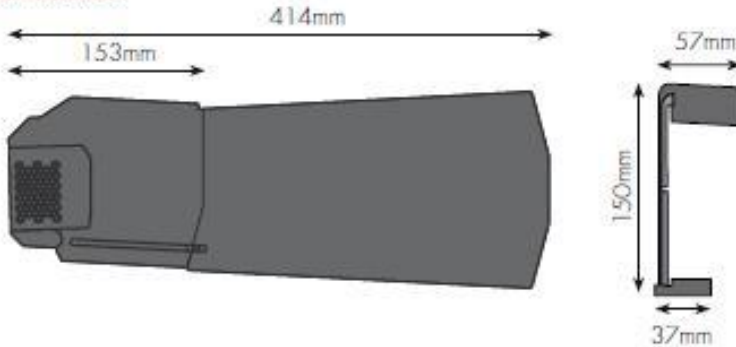

TS05#48 UK0415. We assume no liability for typing errors.

Product codes

Dry Verge Unit left hand

Black	KR9765-0450
Brown	KR9765-0247
Slate Grey	KR9765-0429
Terracotta	KR9765-0152

Dry Verge Unit right hand

Black	KR9770-0450
Brown	KR9770-0247
Slate Grey	KR9770-0429
Terracotta	KR9770-0152

Eaves Ridge Closure

Black	KR973376
Brown	KR973336
Slate Grey	KR973330
Terracotta	KR973334

Half Round Ridge End Caps

Black	KR977276
Brown	KR977236
Slate Grey	KR977230
Terracotta	KR977234

Universal Angle Ridge End Caps

Black	KR977376
Brown	KR977336
Slate Grey	KR977330
Terracotta	KR977334

Packaging

Dry Verge Units

10 units per pack - 5 packs per carton

Eaves Ridge Pack

2 Ridge Closures, 2 Eaves Closures and nails - 20 packs per carton

Ridge End Pack

2 Ridge End Caps and 4 screws - 10 packs per carton

Batten End Clips

50 clips per pack - 10 packs

Weight (per carton)

14.3kg

Regulations

Complies fully with all relevant British Standards

Related products

The Uni-Click® Dry Verge system may be used in conjunction with a wet or dry ridge system of your choice.



Dry Verge System - Uni-Click Fitting Instructions

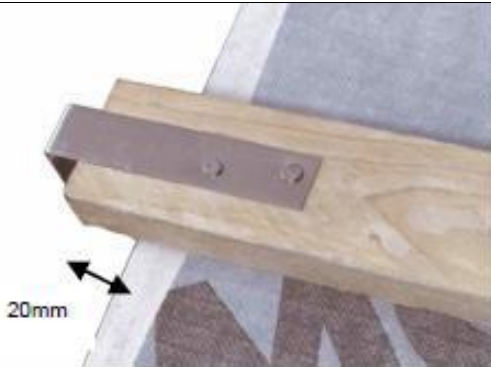

1a. Extend the tiling battens 20mm beyond the gable wall or barge board and nail a Batten End Clip to the end of every batten.

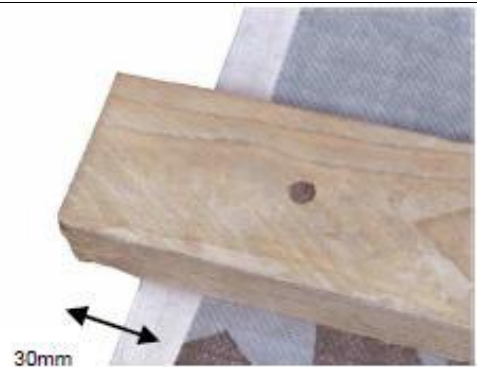

1b. If a batten end clip is not being used, we recommend that the batten is extended 30mm over the barge board or brickwork and 40mm (minimum) x 3.25mm ring shank nails are used to fix the verge units. Prior to fixing the batten, ends must be in good condition with no signs of decay or splitting.



2. Fix the Eaves Closure to the end of the fascia board or brickwork.



3. Fit the first verge section ensuring that it is located onto the eaves closer.



4. Nail in position, through the Batten End Clip into the batten.



5a. Clip the bottom of the verge unit in place first, then lift the top of the verge unit over and clip in to place. As illustrated in stages 5,5a and 5b.

Dry Verge System - Uni-Click Fitting Instructions

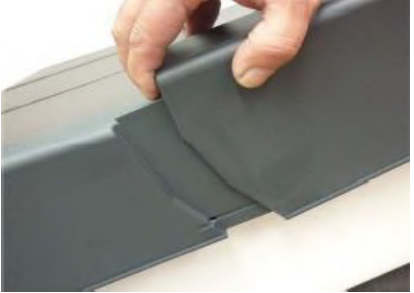
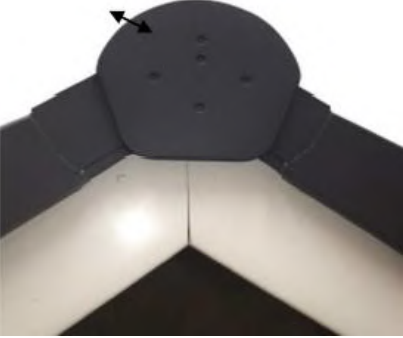
 <p>5a.</p>	 <p>5b.</p>
 <p>6. As each successive verge tile is laid, slide on a Uni-Click Dry Verge Unit up to the bottom of the tile, engaging with the Unit below, nail in position through the Batten End Clip into the batten.</p>	 <p>7. Insert a Ridge Closure into the last unit, interlocking the combs of each Uni-Click Dry Verge Unit at the apex.</p>
 <p>8. Screw fix the Ridge End Cap to the ridge batten.</p>	<p>Colours Slate Grey, Brown, Terracotta, Black</p> <p>Storage Ensure Verge units are not subjected to pressure once they have been removed from the carton e.g. by placing a heavy object on top of the units. This may lead to the units becoming distorted, particularly when stored in a hot location e.g. inside of van.</p>

Retro Fit

If dry verge units are to be fitted to existing buildings all of the old undercloak and mortar bedding should be removed prior to fixing. A timber batten can then be installed running from the eave to ridge, this batten should protrude 30mm over the barge board or brick work/render for the units to fix into (as per step 1a).

Timber Frame

If verge units are to be fitted to timber frame buildings prior to the outer weather covering being applied care should be taken for them to be positioned correctly so when the outer skin of the building is installed the verge units fit correctly and are not in the way of the top of the covering and the gap between the verge unit and the outer skin is maintained. This product should not be installed prior to the outer covering being installed if the eaves closer cannot be fixed.

Pack contents:

Dry Verge Unit: (left hand or right hand) 10 units per pack; 5 packs per carton

Batten End clip: 50 clips per pack; 10 packs per carton

Ridge End Pack: 2 ridge end caps and 4 screws; 10 packs per carton

Eaves Ridge Pack: 2 ridge closures 2 eaves closures and nails; 20 packs per carton

Compatibility

The Uni-Click Dry Verge suits most concrete and clay interlocking tiles between 265 & 350mm batten gauge. The Uni-Click Dry Verge system may be used with the dry ridge system or traditional mortar bedded ridge.

(Note: Batten gauge is measured top of tile batten to top of tile batten)

Dry Verge System – Aluminium slate dry verge

The aluminium Slate Dry Verge System permanently secures slate applications on gable ends protecting the verge from wind uplift and rain. The system is ideal for use with Condron interlocking slates. The components are manufactured from high grade pre-primed polyester coated aluminium & high durability extruded UV inhibited PVC-U.

SLATE DRY VERGE (T2) uPVC

Code	Size	Colour
C02P	18mm x 3m/2.4m/2m	Blk
C02NP	25mm x 3m/2.4m/2m	Blk
*C02LP	32mm x 3m/2.4m/2m	Blk

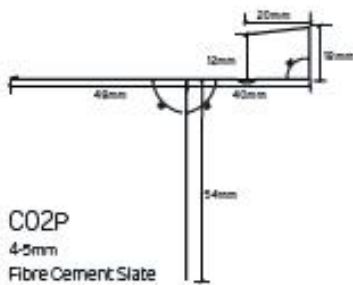
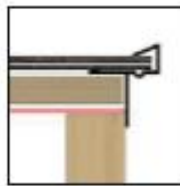

*AVAILABLE
2017

Dry Verge System – Aluminium tile dry verge

The Tile Dry Verge System permanently secures tiles on gable ends and gives an attractive maintenance free finish to the roofline. It provides a neat, continuous and totally weatherproof finish to the gable.

TILE DRY VERGE ALUMINIUM

Code	Size	Colour
C08S	50mm x 3m	Blk • Blue/Blk • Brwn • Wht
C08	65mm x 3m	Blk • Blue/Blk • Brwn • Wht
C08JS	50mm x 3m (Jointer)	Blk • Blue/Blk • Brwn • Wht
C08J	65mm x 3m (Jointer)	Blk • Blue/Blk • Brwn • Wht

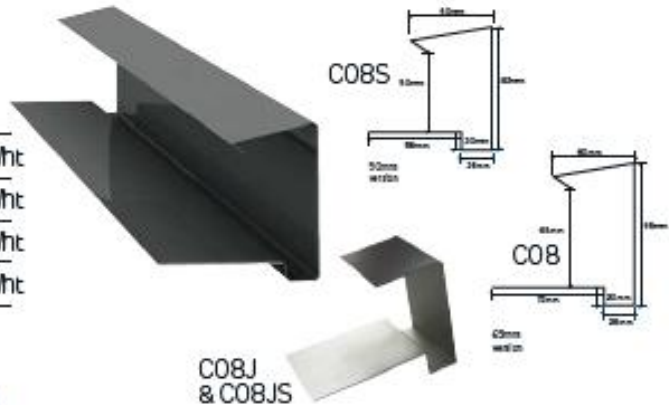

RETRO-FIT TILE DRY VERGE ALUMINIUM

BESPOKE VERSIONS AVAILABLE

Code	Size	Colour
C08ES	50mm x 3m	Blk • Blue/Blk • Brwn • Wht
C08E	65mm x 3m	Blk • Blue/Blk • Brwn • Wht

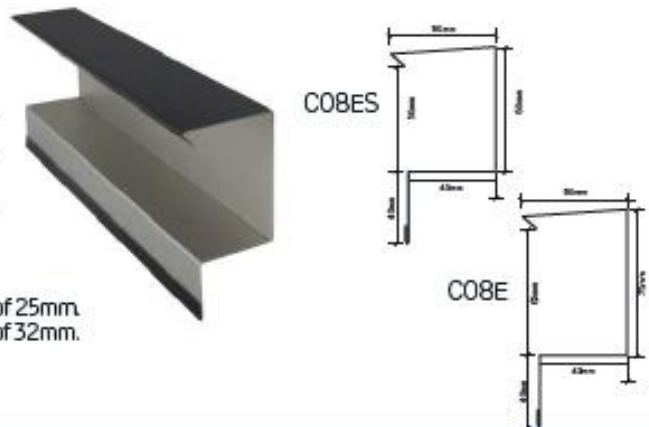

Fully compatible with most tiles on the market.

Suitable for brick, render & bargeboard construction.

50mm Version: Suitable for a maximum individual tile thickness of 25mm.

65mm Version: Suitable for a maximum individual tile thickness of 32mm.

Dry Valley System

GRP Dry Valleys provide a robust, durable and lightweight alternative to lead and zinc valleys.

Product Features & Benefits

- Cost effective alternative to lead
- Lightweight, flexible, safe and easy to cut
- UV resistant
- BBA certified - certificate no 12/4928

Area of Application Suitable for:

- For plain angles of 90° only
- 20° maximum pitch variance
- 17.5° minimum rafter pitch
- 60° maximum rafter pitch

Material

Grey UV stabilised Glass Reinforced Polyester

Dimensions

Slate & Tile Valley Trough 70mm & 110mm 3m long x 400mm wide x 1.1mm

Product Codes / Weight (per pack)

- Dry Slate Valley Trough 70mm
KR966000 25kg
- Dry Tile Valley Trough 110mm
KR966100 29kg

Packaging

Banded in packs of 10 pcs

Regulations

- BBA certified
- Fire tested to comply with BS476: Part 3 SAB and Part 7 Class 3

Performance

- Allow 150mm overlap for rafter pitches 40° – 60°.
- Allow 200mm overlap for rafter pitches 22.5° – 39.5°.
- Allow 250mm overlap for rafter pitches 17.5° – 22°.





Dry Valley System

Installation

Dry valley troughs are suitable for roof pitches up to 60°. It is strongly recommended that where possible, plywood or other suitable valley boards should be used. The underlay material and battens should be fixed in accordance with standard roofing best practice with a batten running the length of the valley on each side to accommodate the external raised water bar section.

When starting at the bottom of the using the dry valley lay a 150mm long GRP pre-cut valley section support should be positioned close to the eaves. Then cut a piece of 300 mm Easy-Form® lead replacement approximately 600 mm long and this should be overlaid onto the GRP pre-cut valley section (ensuring 150mm overlap), ensuring that the Easy-Form® is stuck to the pre-cut valley and lapped over the longitudinal battens. The bottom of the easy form piece should overhang the eaves. The dry valley troughs are fitted onto the valley boards and should be firmly fixed from the Easy-Form® section upwards, using suitable large headed roofing nails on either side of the trough and through the top flat section of the water bar, at a minimum of 500mm centres. All overlaps of troughs and Easy-Form® piece should be at least 150mm. Care should be taken to ensure that the central raised section is not distorted in any way and that it is positioned central to the valley. If the valley trough finishes at a ridge section with a corresponding valley, close off the top piece mitre again Easy-Form® lead replacement flashing is to be used 300 mm x 600 mm. Overlapping the dry valley troughs equally both sides (150 mm) again adhering the Easy-Form® to the GRP dry valley to form a neat and tidy, waterproof seal (as shown in photos above). Tiles or slates being laid into and over the troughs should be laid in accordance with the manufacturer's recommendations. When cutting tiles or slates it is important that neither should be forced to fit. The central raised section of the Dry valley trough should not be distorted. Where possible the roof tiling should be planned to avoid small cut sections. However, in some instances small cuts will be required. Self-adhesive packers are supplied with the valley to support these small cuts if required. When the slating or tiling has been completed, the eaves closure section should be cut with a sharp knife or scissors to allow water discharge into the rainwater gutter. It is important to ensure that the valley troughs are cleared of any debris on completion, so water flow is not impeded.



Dry Valley System – Fitting Instructions

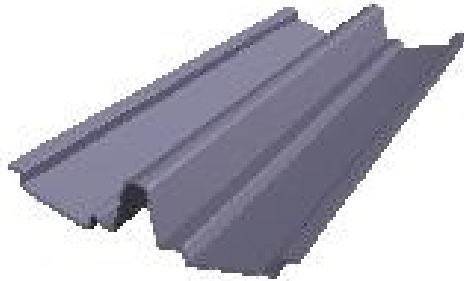

1. Dry valley troughs are suitable for roof pitches up to 60°. Where possible, plywood or other suitable valley boards should be used.
2. The underlay material and battens should be fixed in accordance with standard roofing best practice with a batten running the length of the valley on each side to accommodate the external raised water bar section.
3. When using the eaves closure, the 150mm long GRP pre-cut valley section support should be positioned close to the eaves.
4. The eaves closure piece should be overlaid onto the GRP pre-cut valley section (ensuring 150mm overlap), ensuring that the side winged sections are located over the longitudinal battens. The bottom of the eaves closure piece should overhang the eaves. At the highest point of the eaves closure section a large headed galvanised or aluminium nail should be fixed through the section into the longitudinal batten. Note: A length of flexible packing is supplied with the eaves closure, to use if required to form the continuation of the side support timber battens (when the angle of the valley does not allow the battens to extend to the rear of the fascia board).
5. The dry valley troughs are fitted onto the valley boards and should be firmly fixed from the Easy form section upwards, using suitable large headed roofing nails on either side of the trough and through the top flat section of the water bar, at a minimum of 500mm centres. All overlaps of troughs and Easy Form piece should be at least 150mm. Care should be taken to ensure that the central raised section is not distorted in any way and that it is positioned central to the valley.





Dry Valley System – Fitting Instructions

6. If the valley trough finishes at a ridge section with a corresponding valley, close off the top piece. Easyform lead replacement flashing is to be used 300 mm x 600 mm. Overlapping the dry valley troughs equally both sides (150 mm) again adhering the Easyform to the GRP dry valley to form a neat and tidy, waterproof seal.
7. Tiles or slates being laid into and over the troughs should be laid in accordance with the manufacturer's recommendations. When cutting tiles or slates it is important that neither should be forced to fit. The central raised section of the Dry valley trough should not be distorted.
8. Where possible the roof tiling should be planned to avoid small cut sections. However, in some instances small cuts will be required. Self-adhesive packers are supplied with the valley to support these small cuts if required.

STEP 1



STEP 2



STEP 3



STEP 4



9. When the slating or tiling has been completed, the eaves closure section should be cut with a sharp knife or scissors to allow water discharge into the rain water gutter.
10. It is important to ensure that the valley troughs are cleared of any debris on completion, so water flow is not impeded.





Condron Concrete Works

CONDRON CONCRETE WORKS IS A TRADENAME FOR CONDRON CONCRETE LTD.

ARDEN ROAD, TULLAMORE, CO. OFFALY, IRELAND.

GRP Valley System



GRP Valleys provide a robust, durable and lightweight alternative to lead and zinc valleys.

Product features & benefits

- Cost effective alternative to lead
- Lightweight, flexible, safe and easy to cut
- UV resistant
- BBA certified - certificate no 12/4928



Area of application Suitable for:

- Use on tile and slate pitched roofs
- For plain angles of 90° only
- 20° maximum pitch variance
- 17.5° minimum rafter pitch

Material

Grey UV stabilised Glass Reinforced Polyester

Dimensions

Tile Valley Trough	360	3m long x 360mm wide x 1.1mm
Tile Valley Trough	400	3m long x 400mm wide x 1.1mm
Slate Valley Trough	3m	long x 225mm wide x 1.1mm

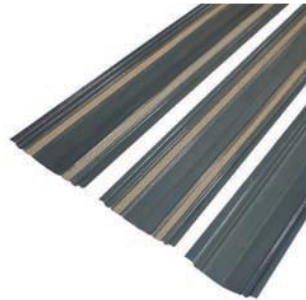

Product Codes / Weight (per pack)

Tile Valley Trough 360	KR965210	24kg
Tile Valley Trough 400	KR965510	29kg
Slate Valley Trough	KR965610	19kg

Packaging

Banded in packs of 10 pcs

Regulations

- BBA certified
- Fire tested to comply with BS476: Part 3 SAB and Part 7 Class 3

Performance

Allow 150mm overlap for rafter pitches 40° – 60°.
 Allow 200mm overlap for rafter pitches 22.5° – 39.5°.
 Allow 250mm overlap for rafter pitches 17.5° – 22°.

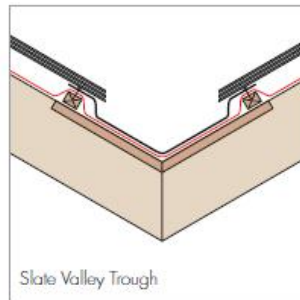
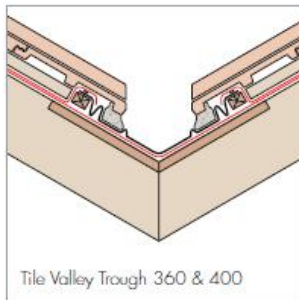

Installation

The GRP Valleys must be laid on valley boards either cut between the valley rafters or a boarding 6mm thick overlaid on top of the valley rafters.

1. Lay 19mm support board cut between rafters and supported on 38 x 25mm noggins nailed to rafters. Top surface of support board must be flush with top of trussed rafter. Alternatively, a 6mm plywood board may be installed on top of the rafters.
2. Position the valley battens along either side of valley.
3. Lay underlay to main roof tiles as normal to finish on top of valley battens.
4. Abut tiling battens to valley on top of the support boards and fix into position.
5. Lay valley trough, allowing overlap at joints cut to suit at ridge and eave.
6. Using clout headed nails, nail to valley battens through 8mm drilled holes, at approximately 1 metre intervals.
7. Lay roof tiles up to valley and cut to rake, various gaps between cut tiles to form open channel, dependent on pitch.
8. Bed tiles with mortar to valley trough sanded strips, ensuring water channels are clear and interlocks are not blocked. For Slate Valley, as above, except that slates do not need to be bedded with mortar but can be laid 'dry'.



Site Practice

INTRODUCTION:

This section is a practical guide to general good practice on site, applicable to all pitched tile roofs. It is based on Code of Practice for Slating and Tiling, S.R. 82:2017, BS 5534:2014+A2:2018 and any new code of practices in the future. The performance of the finished roof is dependent on the design, location, type of roof tile selected, type of felt used and quality of workmanship.

CONCRETE EFFLORESCENCE:

This is a surface phenomenon associated with natural concrete products and influenced by weather conditions. The hydrated lime (calcium hydroxide) in the cement reacts with carbon dioxide in the atmosphere to produce insoluble calcium carbonate, which is deposited as efflorescence. The chemical process of carbonation continues and will eventually form soluble calcium bicarbonate. Normal weathering will wash the bicarbonate away. The degree of efflorescence is relative to lime content and local weather conditions. It is recommended to provide ventilation when using breathable underlay.

It is important to install low and high-level roof-space ventilation when using air and vapour underlays to reduce the amount of water vapour entering the batten cavity (the space between the tiles and underlay) to minimise the risk of efflorescence forming on the undersides of the tiles. At eaves, install Condron OFV Over Fascia Ventilation system. At ridge, install Condron Dry Ventilated Ridge system, ensuring that the underlay is set back from the ridge apex by at least 30mm each side to allow a free flow of air out from the roof space.

In addition, consider providing batten cavity ventilation at low through to high level, combined with 25mm deep counterbattens to remove water vapour which enters the batten cavity

UNDERLAYS MATERIALS:

Underlays which are not fully supported, that is, draped over rafters, should be reinforced type felt IF to IS: 36

LAPS:

Vertical Laps should be not less than 100mm and each end of the underlay should be securely fixed over the rafters. The fixing should be not less than 50mm from the edge of the underlay. The Horizontal lap should be as follows:

Rafter pitches from 17.5 degrees to 55 degrees should have a minimum lap of 150mm and for rafter pitches of 55 degrees and above a minimum lap of 100mm. The Horizontal Laps should, preferably, be under a batten, with at least 25mm of underlay projecting beyond each end of the batten. Where a lap occurs between battens, it should be held down by an extra batten to restrain the laps from opening under wind uplift.

Breathable underlays should be fitted in accordance with manufacturer's instructions and is recommended to use tile vents prevent condensation.

DETAILS:

Eaves: The underlay should drain any water into the eaves gutter and should extend over the tilting piece and fascia board and well into the gutter. Water traps behind the fascia board must be avoided, and a continuous fillet should be fitted to support the felt.

Hips: A strip, not less than 1m wide, should be laid over hips, overlapping the underlay of the main roof.

Valleys: One layer of underlay, 1m wide, should be lapped under the underlay of the main roof.

Verge: Underlay should be carried across the wall cavity.



Site Practice

NAIL HOLES:

Holes in underlay should be kept to a minimum. Where it is necessary to nail underlay, use galvanised clout (large head) nails.

Care should be taken to prevent damaging the underlay and, any damage that does occur, should be properly repaired. It is recommended that at pitches below 25 degrees, and on exposed sites, high performance felt should be used.

SETTING OUT:

Careful setting out makes the actual tiling faster and will contribute to the finished appearance of the roof. It helps to avoid problems such as unequal over-hangs at verges, and often makes it possible to avoid a lot of tile cutting at abutments, chimneys, and similar obstructions.

The area to be tiled should be set out carefully to ensure that:

- Minimum cutting of tiles is necessary.
- The horizontal lines of the course will be regular and true.
- The perpendicular lines of the tile edges will be to a true alignment.
- For regular sized tiles, fit battens to recommended gauge.
- Fix battens, not less than 1200mm long, to each rafter or support, in straight lines, to the calculated gauge, parallel with the ridge or top course, or at right angles to the line of drainage.
- Ensure all joints are square-cut and butted centrally on the supports. Splay nail each batten end.
- For trussed rafter roofs where the batten gauge is greater than 200mm, do not have more than one joint in any four consecutive battens on the same support.
- For trussed rafter roofs where the batten gauge is less than 200mm, do not have more than three joints together in any twelve consecutive battens on the same support.

NOTE:

It may be necessary to retain the alignment of rows of tiling from one roof slope onto projecting roof slopes. This is sometimes referred to as "course through". Where two roof slopes of varying pitch intersect, the required batten gauge should be set out to the lower pitch, so as to maintain the minimum required headlap. This has the effect of reducing the batten gauge and increasing the headlap on the steeper pitch roof.

PERPENDICULARS:

Strike perpendicular chalk lines from eaves to ridge at three tile intervals. Lay tiles, with their edges along these lines, and all will be truly perpendicular.

POSITIONING BATTENS:

For single lap tiles the batten which is to carry the first of eaves course must be positioned so that the bottom edge of the tiles will be over the centre of the gutter. This normally requires an overhang of 50mm to 65mm for a 100mm gutter. Positioning of top and bottom battens must take into account the location of the nibs in relation to the top of the tile. For plain tiles and 3 in 1 tiles, the battens for the eaves undercourse, must be positioned so that the tails of the undercourse and the first tile course line up.

BATTEN GAUGES:

The distance from the top of the eave batten to the top of the top batten must be divided into equal amounts, which must not exceed the gauge recommended for the tile to be fixed.

EAVES FACIA:

The eaves course of tiles must follow the same plane as the rest of the roof. To achieve this, the fascia board must project above the top edge of the rafter by the depth of batten section plus the overall thickness of tile at the bottom edge (plus the thickness of the counter batten on a boarded roof).

BATTENING:

Sizing: Minimum batten sizes (in mm) are shown in Table 1.

Table 1: Minimum Batten Sizes.

Description	Width	Depth
Single Lap tiles	44	35
Plain Tiles / 3 in 1 Tiles	44	35
Pitch Roof	44	35
Vertical Tiling	44	35

Rafter 450mm and 600mm Centres.

BATTEN FIXING:

Battens should be not less than 1200mm in length and should be long enough to be supported at each end and intermediately, by at least three rafters, trusses or walls. Battens must not be cantilevered or spliced between supports. Batten ends should be cut square and nails skew driven on each side of joints. Not more than one batten in four should be joined over any one truss or rafter. Battens on boarded roofs must be supported on counter battens to increase ventilation under the tiles and to allow free drainage of any water that may reach the underlay. Counter battens must be fixed the rough to the rafters, and not to the boarding alone.



Site Practice

TILE FIXING:

(See Tile Fixing Specifications page 34)

MOTAR BEDDING:

All mortar used for bedding Roof Tiles and Accessories, must be 1:3 / sand: cement. Plasticisers may be added in accordance with manufacturer's instructions. Bedding mortar should be squeezed down and struck off to give a clean face. Pointing should not be carried out subsequently or, with different materials. Pigments supplied by Condron Concrete Works may be added, as per manufacturer's instructions.

FLASHINGS AND SOAKERS:

Materials for flashings, soakers and saddles should preferably be lead, to BS1178, of the following minimum thicknesses. Flashings, soakers, saddles, BS code No. 5, 2.24mm thick. Gutters BS code No. 6, 2.5mm thick. Other materials complying with BS5534 may also be used. To avoid the risk of bimetallic corrosion, there should be no contact between different metals, and it is recommended to treat all exposed lead.

RIDGE:

Bedded Ridge: All mortar bedded ridge tiles must be also mechanically fixed. Ridge tiles must be edge bedded and mechanically fixed. No ridge tile should be solid bedded except at butt joints or end of End Ridge. Where solid bedding is required, the mortar should be thinned out with pieces of broken tile to reduce the mass of bedding, and thus, the risk of cracking due to drying shrinkage. Mechanically fix end ridge where possible.

EAVES:

Single Lap Tiles: No mortar or undereaves course is to be used. The eaves course must be in the same plane as the other tiles. Sprocketed eaves are not recommended with single lap tiles.

Plain Tiles: Eaves are to have double courses laid broken bonded throughout, using purpose made undereaves/Top Tile for the undercourse. Tails, or undercourse and first course, should line up.

3 in 1 Tiles: Eaves are to have double courses laid broken bonded throughout, using purpose made Undereaves/Top Tile for the undercourse. Tails, or undercourse and first course, should line up.

VERGES:

Single Lap Tiles: All single lap tiles have their side lock on the left, and work, therefore, must start at the right-hand verge and finish at the left.

Undercloaked Verge: Nail the undercloak to the end rafter, or bed it on to the brick wall ensuring the underlay is under the undercloak. Bed tiles in mortar to form a sloping face, this will assist drainage and give a thinner appearance to the mortar. This is suitable for a 38 to 50mm over-hang. The undercloak course must not tilt inwards.

PLAIN TILES:

Plain tiles are laid broken bonded using Tiles and Tile-and-a-Half in alternate courses at both verges.

No cut tiles should be used at verges. If cutting is necessary, this should be carried out equally on two or three tiles, located some three or four tiles in from the verge.

3 IN 1 TILES:

3 in 1 Tiles are laid broken bonded, using Tiles and Tile and-a-Half in alternate courses at both verges. No cut tiles should be used at verges.

ABUTMENTS:

Tile or cement fillets should not be used. Use Tiles and Half Tiles etc., as for verges, to minimise cutting and maintain broken bond where appropriate.

VALLEYS & HIPS:

Tile Cutting: For making cuts at valleys and hips, mechanical cutting is preferable to hand cutting since it gives a better appearance and avoids small body cracks.

Fixing: All cut tiles must be carefully bedded in mortar. If the nail holes are cut away, the side of the piece must be notched, and supported with a nail.

When forming a valley with interlocking tiles, great care must be taken not to leave any mortar in the sidelocks of the cut tiles; otherwise water will build up in the channels and spill back into the roof. For lead valleys, lengths of lead sheet should not exceed 1.5m with laps of 150mm. Provision should be made for a slip layer between the mortar bedding and the lead sheet. Hip Tiles should be edge bedded in mortar, with solid bedding at butt joints.



Condron Concrete Works

CONDRON CONCRETE WORKS IS A TRADENAME FOR CONDRON CONCRETE LTD.

ARDEN ROAD, TULLAMORE, CO. OFFALY, IRELAND.

VERTICAL TILING:

Vertical tiling may be fixed to battens, or to battens on counter battens. Counter battening reduces the amount of fixing direct to a solid wall. When tiling to a timber framed construction, a suitable breather membrane or vapour barrier must be provided as appropriate.

Spacing of counter battens should not exceed those given in BS5534. The top edge should incorporate an Eaves/Top Tile: when under a windowsill, or soffit, a lead flashing should be dressed down over the top course. The bottom edge should have double coursing throughout, using Eaves/Top Tiles for the undercourse. For abutments etc. use Tiles and Tile-and-a-Half tiles in alternate courses to maintain broken bond.

SURFACE COATING:

Condron Concrete Works roof tiles are surface treated with an acrylic coating (**See Climatic Conditions P27**). The performance of the roof tile is not affected by any of the above conditions and the quality requirements of the tile remain intact, see Annex A, BS EN 490

SCRATCHES & ABRASIONS:

These can be caused by packing, loading, transport and handling on site: These are surface marks that will not affect the overall quality of the tile and will become less apparent with natural weathering, see Annex A, BS EN 490.

MOSSES & LICHENS:

Mosses and lichen tend to grow on roofs located in the vicinity of trees, or in shady damp conditions. North facing slopes remain damper longer and attract moss and lichen growth more so than roof slopes which dry out quicker. Neither the material content nor the production process cause lichen growth or moss formation.

NOTE: Reference should be made to Code of Practice for Slating and Tiling, S.R. 82:2017, BS 5534:2014+A2: 2018 and any new code of practices in the future. Condron Concrete Roof Tiles are manufactured in compliance with E.N. 490:2011+A1: 2017 Concrete Roofing Tiles & Fittings.



Condron Concrete Works

CONDRON CONCRETE WORKS IS A TRADENAME FOR CONDRON CONCRETE LTD.

ARDEN ROAD, TULLAMORE, CO. OFFALY, IRELAND.

Site Practice

SAFETY:

Attention is drawn to Regulations 76 and 77 of the Safety, Health and Welfare at Work (Construction) Regulations 1995. These notes are a brief summary of safety precautions based on The 1995 Regulations made under the Safety, Health and Welfare at Work Act 1989. It is the responsibility of employers, employees, and the self-employed, to ensure that legal requirements are complied with. Particular attention is drawn to the Safety, Health and Welfare at Work (Construction) Regulations 1995 and other legislation setting out the duties of owners, employers and employees in relation to the construction and maintenance of buildings. Any form of completed roof or vertical work must be treated as fragile. An adequate number of crawling boards, ladders, hooks etc.... should be used, properly supported, securely fixed and anchored, in such a manner as to prevent slipping or tipping. In some cases, it will be necessary to provide parallel sets of crawling boards, with a bridge between, to form a working platform. In addition, where a person is liable to fall more than 2.00m from the lower edge of a sloping roof, a barrier must be provided at that edge to prevent such a fall. Alternatively, the work must be done from a securely supported working platform, fitted with guard rails and toe boards. The regulations also require precautions to be taken when access ladders are used. The requirements to secure ladders should be particularly noted.

Ladders should not be rested against verges because of the uneven support and the risk of damage. Similarly, to avoid damage to eaves gutters, ladders should not be rested against gutters, but blocked out to clear the gutter, and then secured. Great care should be used when fixing eaves gutters immediately below valleys, particularly where valley troughs are used, as these are vulnerable to breakage. Packing (e.g.: sacking, rubber sheet) should be used under crawling boards, ladders, hooks, etc, to protect the tiles from possible breakage. Materials and tools should be carried, not dragged over the roof. Materials stacked on the roof, should not overload the battens, boarding or roof structure, and should be evenly distributed to avoid permanent distortion of the roof.

NOTE:

Above notes are given for general information guidance only and are not to be taken as comprehensive. All Condron Concrete Works Drivers have Hard Hats, Steel - Toe Boots, Safety Jackets and Safety Passes.

Tile Pallet Weights

Description	Number of Tiles per Pallet	Palate Weight kgs (Approx.)
Condron Concrete Pantile	240	1220
Condron Concrete Slate Tile	240	1340
Condron Concrete Slate Tile	180	1020
Condron Concrete "Bullnose" Slate Tile	240	1340
Condron Concrete "Bullnose" Slate Tile	180	1020
Condron Concrete 3 in 1 Tile/Cladding Tile	288	1280
Condron Concrete Plain Tile/Cladding Tile	180	1020
Condron Concrete "M Profile" Tile	240	1180
The Condron Slate	288	880
The Senior Slate	240	1240
Ridge Tiles	100	840

NOTE: All weights are approximate.

NOTE

The information given in this manual, is, to the best of our knowledge correct, but customers, including Designers and Specifiers, must satisfy themselves, that all products chosen are suitable for their specific requirements. Condron Concrete Works, or their employees, or agents, do not accept any liability whatsoever arising from anything contained in this manual.



Condron Concrete Works

CONDRON CONCRETE WORKS IS A TRADENAME FOR CONDRON CONCRETE LTD.

ARDEN ROAD, TULLAMORE, CO. OFFALY, IRELAND.

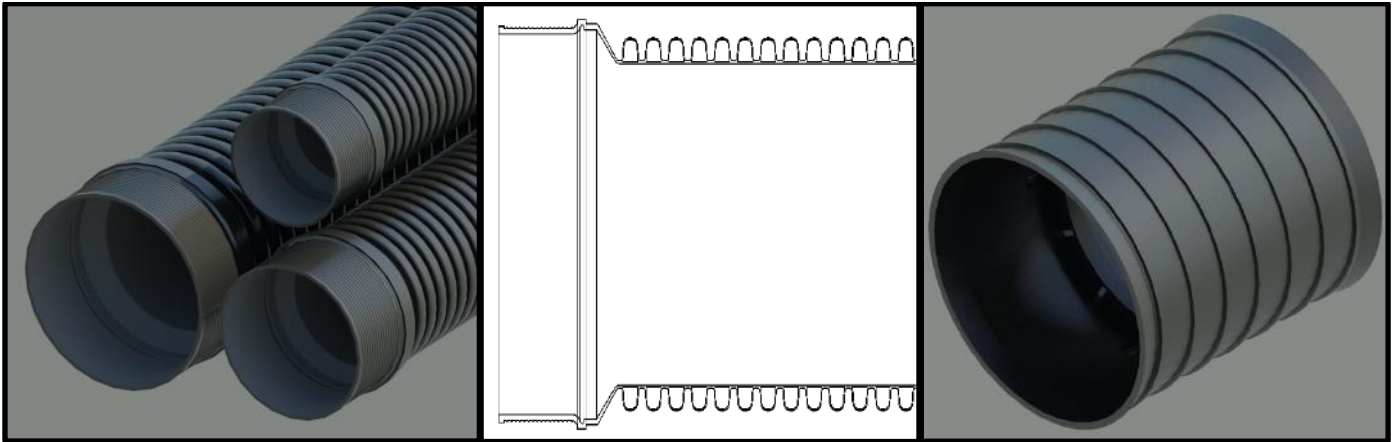

Plastic & Concrete Pipes for Water Drainage Systems and Underground Ducting Systems



Condron Concrete Works, Arden Road, Tullamore,
Co. Offaly. Telephone: +353 (057) 9349000-9

Fax: +353 (057) 9341565

Email: condronconcrete@eircom.net or
Web: www.condronconcrete.com

